

CE EMC TEST REPORT

for

eBOX

MODEL: eBOX700-891-FL

Test Report Number:
T171211D09-E

Issued to:

AXIOMTEK CO., LTD.

**8F., No.55, Nanxing Road, Xizhi District,
New Taipei City 221, Taiwan**

Issued by:

Compliance Certification Services Inc.

Xindian Lab.

**No.163-1, Jhongsheng Rd., Xindian Dist.,
New Taipei City, 23151 Taiwan.**

TEL: 886-2-22170894

FAX: 886-2-22171029

Issued Date: January 2, 2018



Note: This report shall not be reproduced except in full, without the written approval of Compliance Certification Services Inc. This document may be altered or revised by Compliance Certification Services Inc. personnel only, and shall be noted in the revision section of the document. The client should not use it to claim product endorsement by TAF, A2LA, NVLAP, NIST or any government agencies. The test results in the report only apply to the tested sample.

Revision History

Rev.	Issue Date	Revisions	Effect Page	Revised By
00	January 2, 2018	Initial Issue	ALL	Amy Wang

TABLE OF CONTENTS

1 TEST CERTIFICATION 4

2 TEST RESULT SUMMARY 5

3 EUT DESCRIPTION 6

4 TEST METHODOLOGY 7

4.1. DECISION OF FINAL TEST MODE.....7

4.2. EUT SYSTEM OPERATION7

5 SETUP OF EQUIPMENT UNDER TEST 8

5.1. DESCRIPTION OF SUPPORT UNITS.....8

5.2. CONFIGURATION OF SYSTEM UNDER TEST9

6 FACILITIES AND ACCREDITATIONS 10

6.1. FACILITIES10

6.2. ACCREDITATIONS10

6.3. MEASUREMENT UNCERTAINTY.....10

7 EMISSION TEST 11

7.1. CONDUCTED EMISSION MEASUREMENT.....11

7.2. REQUIREMENTS FOR ASYMMETRIC MODE CONDUCTED EMISSIONS.....16

7.3. RADIATED EMISSION MEASUREMENT.....20

7.4. CONDUCTED DIFFERENTIAL VOLTAGE EMISSIONS FROM CLASS B EQUIPMENT.29

7.5. HARMONICS CURRENT MEASUREMENT.....32

7.6. VOLTAGE FLUCTUATION AND FLICKER MEASUREMENT37

8 IMMUNITY TEST 39

8.1. GENERAL DESCRIPTION39

8.2. GENERAL PERFORMANCE CRITERIA DESCRIPTION.....40

8.3. ELECTROSTATIC DISCHARGE (ESD)41

8.4. RADIATED, RADIO-FREQUENCY, ELECTROMAGNETIC FIELD (RS)48

8.5. ELECTRICAL FAST TRANSIENT (EFT)51

8.6. SURGE IMMUNITY TEST54

8.7. CONDUCTED RADIO FREQUENCY DISTURBANCES (CS).....57

8.8. POWER FREQUENCY MAGNETIC FIELD.....59

8.9. VOLTAGE DIPS & VOLTAGE INTERRUPTIONS61

9 PHOTOGRAPHS OF THE TEST CONFIGURATION..... 63

APPENDIX 1 - PHOTOGRAPHS OF EUTA1-1

1 TEST CERTIFICATION

Product:	eBOX	
Model:	eBOX700-891-FL	
Brand:	AXIOMTEK	
Applicant:	AXIOMTEK CO., LTD. 8F., No.55, Nanxing Road, Xizhi District, New Taipei City 221, Taiwan	
Manufacturer:	AXIOMTEK CO., LTD. 8F., No.55, Nanxing Road, Xizhi District, New Taipei City 221, Taiwan	
Tested:	December 29, 2017	
Applicable Standards:	EN 55032: 2015 / AC: 2016, Class A CISPR 32: 2015 (Ed 2.0) / C1: 2016 EN 61000-3-2: 2014 EN 61000-3-3: 2013	EN 55024: 2010 + A1: 2015 IEC 61000-4-2: 2008 IEC 61000-4-3: 2006 + A1: 2007 + A2: 2010 IEC 61000-4-4: 2012 IEC 61000-4-5: 2014 IEC 61000-4-6: 2013 IEC 61000-4-8: 2009 IEC 61000-4-11: 2004

Deviation from Applicable Standard
None

The above equipment was tested by Compliance Certification Services Inc. for compliance with the requirements of technical standards specified above under the EMC Directive 2014/30/EU. The results of testing in this report apply only to the product/system, which was tested. Other similar equipment will not necessarily produce the same results due to production tolerance and measurement uncertainties.

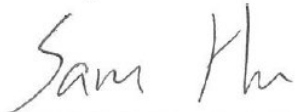
Approved by:

 Sam Hu
 Assistant Manager

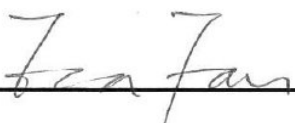
Reviewed by:

 Eva Fan
 Supervisor of report document dept.

2 TEST RESULT SUMMARY

EMISSION			
Standard	Item	Result	Remarks
EN 55032: 2015 / AC: 2016 CISPR 32: 2015 (Ed 2.0) / C1: 2016	Conducted (Power Port)	PASS	Meet Class A limit
	Conducted (Telecom port)	PASS	Meet Class A limit
	Radiated	PASS	Meet Class A limit
	Radiated emissions from FM receivers	N/A	Please see the page 28
	Conducted differential voltage emissions from Class B equipment	N/A	Please see the page 31
EN 61000-3-2: 2014	Harmonic current emissions	PASS	Meet Class A limit
EN 61000-3-3: 2013	Voltage fluctuations & flicker	PASS	Meets the requirements

IMMUNITY [EN 55024: 2010 + A1: 2015]			
Standard	Item	Result	Remarks
IEC 61000-4-2: 2008	ESD	PASS	Meets the requirements of Performance Criterion A
IEC 61000-4-3: 2006 + A1: 2007 + A2: 2010	RS	PASS	Meets the requirements of Performance Criterion A
IEC 61000-4-4: 2012	EFT	PASS	Meets the requirements of Performance Criterion A
IEC 61000-4-5: 2014	Surge	PASS	Meets the requirements of Performance Criterion A
IEC 61000-4-6: 2013	CS	PASS	Meets the requirements of Performance Criterion A
IEC 61000-4-8: 2009	PFMF	N/A	Please see the page 60
IEC 61000-4-11: 2004	Voltage dips & voltage variations	PASS	Meets the requirements of Voltage Dips: 1) >95% reduction Performance Criterion A 2) 30% reduction Performance Criterion A Voltage Interruptions: 1) >95% reduction Performance Criterion C

- Note:**
1. The statements of test result on the above are decided by the request of test standard only; the measurement uncertainties are not factored into this compliance determination.
 2. The information of measurement uncertainty is available upon the customer's request.

3 EUT DESCRIPTION

Product	eBOX
Brand Name	AXIOMTEK
Model	eBOX700-891-FL
Applicant	AXIOMTEK CO., LTD.
Housing material	Metal case
Identify Number	T171211D09
Received Date	December 11, 2017
EUT Power Rating	24VDC from AC Adapter
AC Power During Test	110VAC / 50Hz & 230VAC / 50Hz to AC Adapter
Adaptor Manufacturer	FSP
Adaptor Model Number	FSP120-AAAN3
Adaptor Power Rating	Input: 100-240VAC~, 1.8A, 50-60Hz Output: 24VDC, 5.0A
DC Power Cable Type	Unshielded, 1.6m (Non-detachable, with a core)

I/O PORT

I/O PORT TYPES	Q'TY	TESTED WITH
1. COM Port	2	2
2. Microphone Port	1	1
3. Earphone Port	1	1
4. HDMI Port	2	2
5. LAN Port	4	4
6. Display Port	1	1
7. USB 2.0 Port	2	2
8. USB 3.0 Port	4	4

Note: Client consigns only one model sample to test (Model Number: eBOX700-891-FL).

4 TEST METHODOLOGY

4.1. DECISION OF FINAL TEST MODE

The EUT was tested together with the below additional components, and a configuration, which produced the worst emission levels, was selected and recorded in this report.

The test configuration/ modes are as the following:

Conduction Modes:

1	HDMI 1 + HDMI 2 1920X1200, VF=60Hz Mode	110VAC / 50Hz
2		230VAC / 50Hz
3	HDMI 1 + DP 1920X1200, VF=60Hz Mode	110VAC / 50Hz

Conduction Modes (Telecom port):

1	LAN 1	1Gbps
2	LAN 4	10Mbps
3		100Mbps
4		1Gbps

Radiation Modes:

1	HDMI 1 + HDMI 2 1920X1200, VF=60Hz Mode	110VAC / 50Hz
2	HDMI 1 + HDMI 2 1920X1200, VF=60Hz Mode	230VAC / 50Hz
	HDMI 1 + HDMI 2 1920X1200, VF=60Hz Mode / 1-6GHz	
3	HDMI 1 + DP 1920X1200, VF=60Hz Mode	110VAC / 50Hz

Worst:

Conduction (Power port): Mode 1

Conduction (Telecom port): Mode 4

Radiation: Mode 2

4.2. EUT SYSTEM OPERATION

1. Windows 10 boots system.
2. Run colorbarmove.exe to activate all peripherals for test EUT.
3. Run Burnintest.exe to test EUT.
4. Press the start menu, select executive and type ping 192.168.0.1~4 -t (EUT), ping 192.168.0.11~14 -t (Server PC).

Note: Test program is self-repeating throughout the test.

5 SETUP OF EQUIPMENT UNDER TEST

5.1. DESCRIPTION OF SUPPORT UNITS

The EUT has been tested as an independent unit together with other necessary accessories or support units. The following support units or accessories were used to form a representative test configuration during the tests.

EUT Devices:

No	Equipment	Model	Brand Name
1	Motherboard	SBC87891	AXIOMTEK
2	CPU (3.70GHz)	Intel(R) Core(TM) i3-6100	Intel
3	Memory (DDR4 / 2400 / 8GB)	N/A	Transcend
4	SSD (32GB)	N/A	CoreSolid Storage

Peripherals Devices:

No.	Equipment	Model No.	Serial No.	FCC ID / BSMI ID	Brand Name	Data Cable	Power Cord
1	USB Mouse	M-U0026	N/A	DOC BSMI: T41126	Logitech	Shielded, 1.8m	N/A
2	USB Keyboard	Y-U0011	N/A	DOC BSMI: T51160	Logitech	Shielded, 1.8m	N/A
3	Earphone & Microphone	JAZZ-520	N/A	N/A	INTOPIC	Unshielded, 1.8m	N/A
4	Monitor	PA248Q	G5LMQS071284	DOC BSMI: R31018	ASUS	HDMI: Shielded, 1.8m DP: Shielded, 1.8m	Unshielded, 1.8m
5~6	USB HDD	HD-EG5	N/A	DOC BSMI: D33021	SONY	Shielded, 0.6m	N/A
7~8	COM Connector	N/A	N/A	N/A	N/A	N/A	N/A
9~10	USB HDD	HD-EG5	N/A	DOC BSMI: D33021	SONY	Shielded, 0.6m	N/A
11	Monitor	PA248Q	G5LMQS071170	DOC BSMI: R31018	ASUS	Shielded, 1.8m	Unshielded, 1.8m
12~15	Server PC	T3500	N/A	DOC BSMI: R33002	DELL	Unshielded, 20m	Unshielded, 1.8m

Note:

- 1) All the equipment/cables were placed in the worst-case configuration to maximize the emission during the test.
- 2) Grounding was established in accordance with the manufacturer's requirements and conditions for the intended use.

5.2. CONFIGURATION OF SYSTEM UNDER TEST

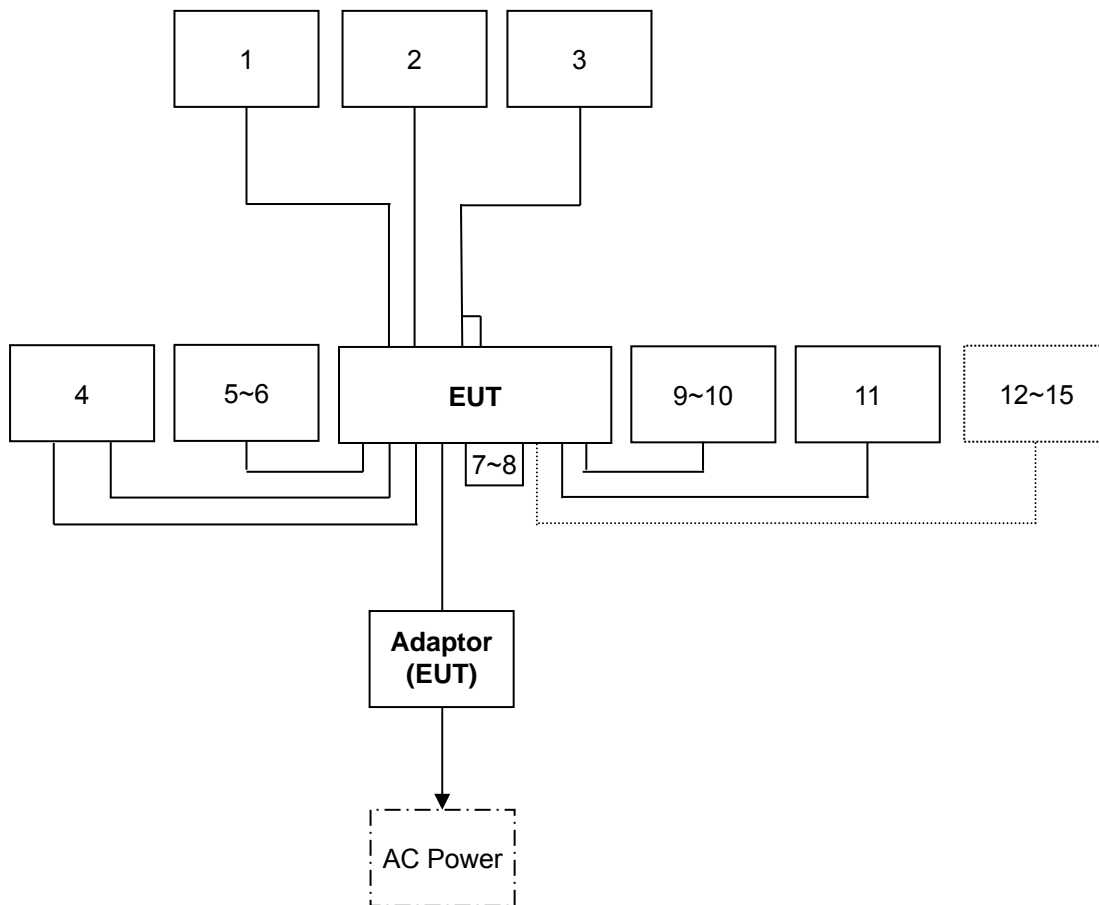

6 FACILITIES AND ACCREDITATIONS

6.1. FACILITIES

All measurement facilities used to collect the measurement data are located at CCSrf Taiwan Xindian Lab. at No.163-1, Jhongsheng Rd., Xindian Dist., New Taipei City, 23151 Taiwan.

The sites are constructed in conformance with the requirements of ANSI C63.4 and CISPR Publication 22. All receiving equipment conforms to CISPR 16-1-1, CISPR 16-1-2, CISPR 16-1-3, CISPR 16-1-4 and CISPR 16-1-5.

6.2. ACCREDITATIONS

Our laboratories are accredited and approved by the following accreditation body according to ISO/IEC 17025.

Taiwan	TAF
USA	A2LA

The measuring facility of laboratories has been authorized or registered by the following approval agencies.

Canada	Industry Canada
Japan	VCCI
Taiwan	BSMI
USA	FCC

Copies of granted accreditation certificates are available for downloading from our web site, <http://www.ccsrf.com>

6.3. MEASUREMENT UNCERTAINTY

Where relevant, the following measurement uncertainty levels have been estimated for tests performed on the EUT as specified in CISPR 16-4-2:

Measurement	Frequency	Uncertainty
Conducted emissions (Power port)	0.15MHz ~ 30MHz	± 1.07
Conducted emissions (Telecom port)	0.15MHz ~ 30MHz	± 1.60
Radiated emissions	30MHz ~ 1000MHz	± 4.82
	1000MHz ~ 6000MHz	± 4.03

This uncertainty represents an expanded uncertainty expressed at approximately the 95% confidence level using a coverage factor of k=2.

Consistent with industry standard (e.g. CISPR 22: 2005, clause 11, Measurement Uncertainty) determining compliance with the limits shall be base on the results of the compliance measurement. Consequently the measure emissions being less than the maximum allowed emission result in this be a compliant test or passing test.

The acceptable measurement uncertainty value without requiring revision of the compliance statement is base on conducted and radiated emissions being less than U_{CISPR} which is 3.6dB and 5.2dB respectively. CCS values (called U_{Lab} in CISPR 16-4-2) is less than U_{CISPR} as shown in the table above. Therefore, MU need not be considered for compliance.

7 EMISSION TEST

7.1. CONDUCTED EMISSION MEASUREMENT

7.1.1. LIMITS

FREQUENCY (MHz)	Class A (dBuV)		Class B (dBuV)	
	Quasi-peak	Average	Quasi-peak	Average
0.15 - 0.5	79	66	66 - 56	56 - 46
0.50 - 5.0	73	60	56	46
5.0 - 30.0	73	60	60	50

NOTE:

- (1) The lower limit shall apply at the transition frequencies.
- (2) The limit decreases in line with the logarithm of the frequency in the range of 0.15 to 0.50 MHz.
- (3) All emanations from a class A/B digital device or system, including any network of conductors and apparatus connected thereto, shall not exceed the level of field strengths specified above.

7.1.2. TEST INSTRUMENTS

Conducted Emission room # A				
Name of Equipment	Manufacturer	Model	Serial Number	Calibration Due
BNC Cable	EMEC	EMG178	BNC#A9	03/27/2018
EMI Test Receiver	R&S	ESCI	101201	08/22/2018
LISN	Schwarzbeck	NNLK 8129	8129-286	08/15/2018
LISN(EUT)	Schwarzbeck	NSLK 8127	8127527	08/15/2018
Pulse Limiter	R&S	ESH3Z2	C3010026-2	08/17/2018
Thermo-Hygro Meter	Wisewind	201A	No. 02	05/08/2018
Test S/W	EZ-EMC			

- NOTE:** 1. The calibration interval of the above test instruments is 12 months and the calibrations are traceable to NML/ROC and NIST/USA.
 2. N.C.R = No Calibration Request.

7.1.3. TEST PROCEDURES (please refer to measurement standard or CCS SOP PA-031 & PA-041)**Procedure of Preliminary Test**

- The EUT and Support equipment, if needed, was set up as per the test configuration to simulate typical usage per the user's manual. When the EUT is a tabletop system, a wooden table with a height of 0.8 meters is used and is placed on the ground plane as per EN 55032 (see Test Facility for the dimensions of the ground plane used). When the EUT is a floor standing equipment, it is placed on the ground plane, which has a 15 cm non-conductive covering to insulate the EUT from the ground plane.
- All I/O cables were positioned to simulate typical actual usage as per EN 55032.
- The test equipment EUT installed received AC main power, through a Line Impedance Stabilization Network (LISN), which supplied power source and was grounded to the ground plane.
- All support equipment power received from a second LISN.
- The EUT test program was started. Emissions were measured on each current carrying line of the EUT using an EMI Test Receiver connected to the LISN powering the EUT.
- The Receiver scanned from 150kHz to 30MHz for emissions in each of the test modes.
- During the above scans, the emissions were maximized by cable manipulation.
- The test mode(s) described in Item 4.1 were scanned during the preliminary test.
- After the preliminary scan, we found the test mode described in Item 4.1 producing the highest emission level.
- The EUT configuration and cable configuration of the above highest emission levels were recorded for reference of the final test.

Procedure of Final Test

- EUT and support equipment were set up on the test bench as per the configuration with highest emission level in the preliminary test.
- A scan was taken on both power lines, Line 1 and Line 2, recording at least the six highest emissions. Emission frequency and amplitude were recorded into a computer in which correction factors were used to calculate the emission level and compare reading to the applicable limit.
- The test data of the worst-case condition(s) was recorded.

7.1.4. TEST SETUP

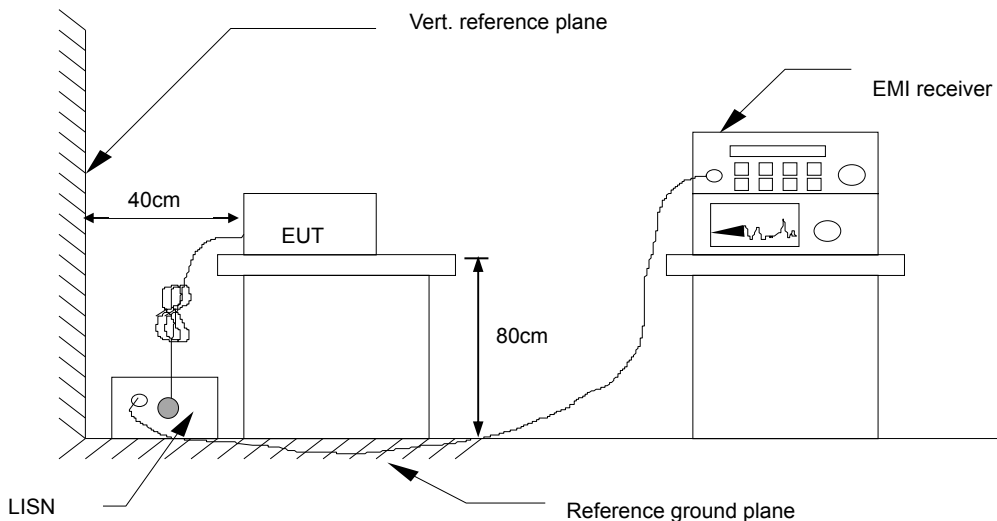

- For the actual test configuration, please refer to the related item – Photographs of the Test Configuration.

7.1.5. DATA SAMPLE

Freq. (MHz)	Reading (dBuV)	Factor (dB)	Result (dBuV)	Limit (dBuV)	Margin (dB)	Detector (P/Q/A)	Line (L1/L2)
x.xx	42.95	0.55	43.50	73	-29.50	Q	L1

- Freq. = Emission frequency in MHz
- Reading = Uncorrected Analyzer/Receiver reading
- Factor = Insertion loss of LISN + Cable Loss + Pulse Limit
- Result = Reading + Factor
- Limit = Limit stated in standard
- Margin = Reading in reference to limit
- P = Peak Reading
- Q = Quasi-peak Reading
- A = Average Reading
- L1 = Hot side
- L2 = Neutral side

Calculation Formula

Margin (dB) = Result (dBuV) – Limit (dBuV)

7.1.6. TEST RESULTS

Model No.	eBOX700-891-FL	6dB Bandwidth	9 kHz
Environmental Conditions	21°C, 49% RH	Test Mode	Mode 1
Tested by	Bonny Tsai	Phase	L1
Standard	EN 55032 CLASS A		

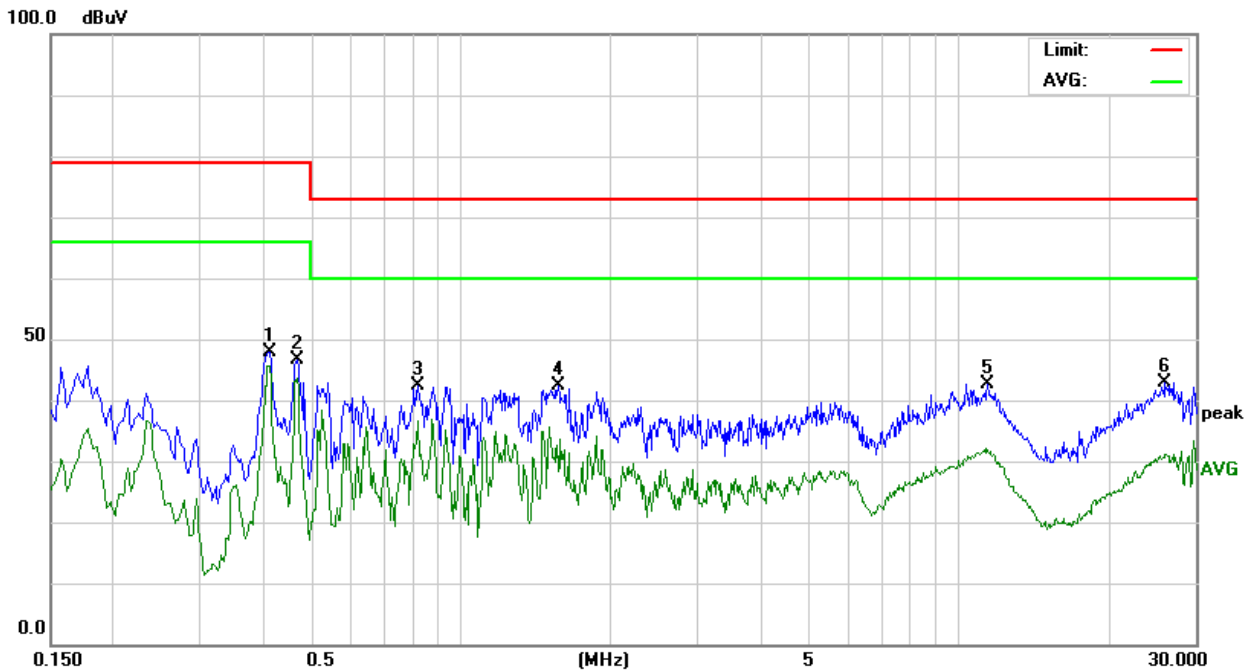

Conducted Emission Readings							
Frequency Range Investigated				150 kHz to 30 MHz			
Freq. (MHz)	Reading (dBuV)	Factor (dB)	Result (dBuV)	Limit (dBuV)	Margin (dB)	Detector (P/Q/A)	Line (L1/L2)
0.4140	37.77	10.04	47.81	79.00	-31.19	P	L1
0.4700	36.49	10.04	46.53	79.00	-32.47	P	L1
0.8220	32.24	10.09	42.33	73.00	-30.67	P	L1
1.5740	32.15	10.17	42.32	73.00	-30.68	P	L1
11.4579	32.04	10.62	42.66	73.00	-30.34	P	L1
26.0500	31.79	11.19	42.98	73.00	-30.02	P	L1

Note: 1. L1 = Line One (Live Line) / L2 = Line Two (Neutral Line).

Model No.	eBOX700-891-FL	6dB Bandwidth	9 kHz
Environmental Conditions	21°C, 49% RH	Test Mode	Mode 1
Tested by	Bonny Tsai	Phase	L2
Standard	EN 55032 CLASS A		

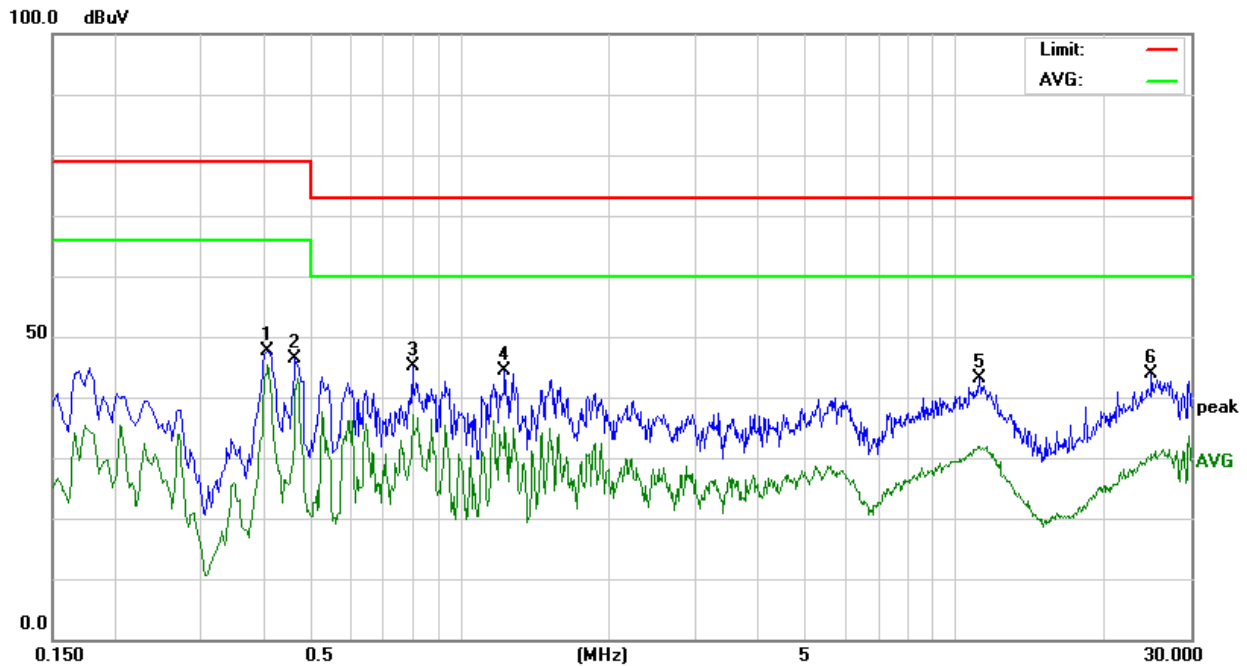

Conducted Emission Readings							
Frequency Range Investigated				150 kHz to 30 MHz			
Freq. (MHz)	Reading (dBuV)	Factor (dB)	Result (dBuV)	Limit (dBuV)	Margin (dB)	Detector (P/Q/A)	Line (L1/L2)
0.4100	37.62	10.04	47.66	79.00	-31.34	P	L2
0.4660	36.38	10.04	46.42	79.00	-32.58	P	L2
0.8020	34.93	10.09	45.02	73.00	-27.98	P	L2
1.2300	34.31	10.14	44.45	73.00	-28.55	P	L2
11.2179	32.48	10.62	43.10	73.00	-29.90	P	L2
24.9820	32.70	11.14	43.84	73.00	-29.16	P	L2

Note: 1. L1 = Line One (Live Line) / L2 = Line Two (Neutral Line).

7.2. REQUIREMENTS FOR ASYMMETRIC MODE CONDUCTED EMISSIONS

7.2.1. LIMITS

For Class A Equipment

FREQUENCY (MHz)	Voltage Limit (dBuV)		Current Limit (dBuA)	
	Quasi-peak	Average	Quasi-peak	Average
0.15 ~ 0.5	97 ~ 87	84 ~ 74	53 ~ 43	40 ~ 30
0.5 ~ 30.0	87	74	43	30

NOTE: The limits decrease linearly with the logarithm of the frequency in the range 0.15 MHz to 0.5 MHz.

For Class B Equipment

FREQUENCY (MHz)	Voltage Limit (dBuV)		Current Limit (dBuA)	
	Quasi-peak	Average	Quasi-peak	Average
0.15 - 0.5	84 ~ 74	74 ~ 64	40 ~ 30	30 ~ 20
0.5 - 30.0	74	64	30	20

NOTE: The limits decrease linearly with the logarithm of the frequency in the range 0.15 MHz to 0.5 MHz.

7.2.2. TEST INSTRUMENTS

Conducted Emission room # A				
Name of Equipment	Manufacturer	Model	Serial Number	Calibration Due
BNC Cable	EMEC	EMG178	BNC#A9	03/27/2018
EMI Test Receiver	R&S	ESCI	101201	08/22/2018
LISN	Schwarzbeck	NNLK 8129	8129-286	08/15/2018
LISN(EUT)	Schwarzbeck	NSLK 8127	8127527	08/15/2018
Pulse Limiter	R&S	ESH3Z2	C3010026-2	08/17/2018
Thermo-Hygro Meter	Wisewind	201A	No. 02	05/08/2018
ISN	Teseq	ISN T800	29449	08/15/2018
Test S/W	EZ-EMC			

NOTE: 1. The calibration interval of the above test instruments is 12 months and the calibrations are traceable to NML/ROC and NIST/USA.
 2. N.C.R = No Calibration Request.

7.2.3. TEST PROCEDURE (please refer to measurement standard or CCS SOP PA-031)

- Selecting ANN for unscreened cable or a current probe for screened cable to take measurement.
- The port of the EUT was connected to the remote side support equipment through the ANN/Current Probe and communication in normal condition.
- Making a overall range scan by using the test receiver controlled by controller and record at least six highest emissions for showing in the test report.
- Emission frequency and amplitude were recorded into a computer in which correction factors were used to calculate the emission level and compare reading to the applicable limit.
- In case of measuring on the screened cable, the current limit shall be applied; otherwise the voltage limit should be applied.
- The following test modes was scanned during the preliminary test:

Modes:

1	LAN 1	1Gbps
2	LAN 4	10Mbps
3		100Mbps
4		1Gbps

- After the preliminary scan, we found the following test mode(s) producing the highest emission level and test data of the worst case was recorded.

Mode: 4

7.2.4. TEST SETUP

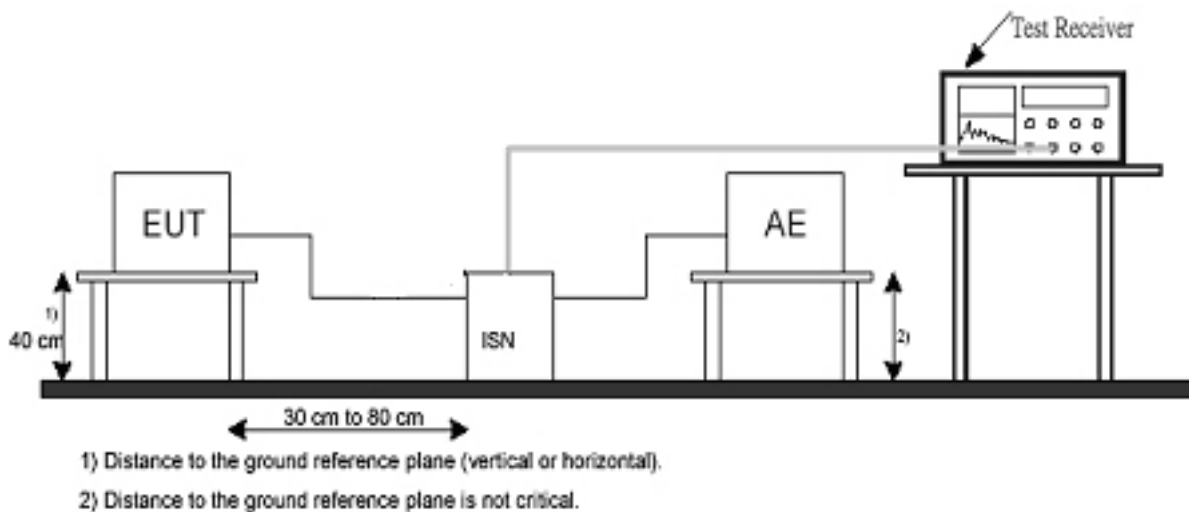

- For the actual test configuration, please refer to the related item – Photographs of the Test Configuration.

7.2.5. DATA SAMPLE

Freq. (MHz)	Reading (dBuV)	Factor (dB)	Result (dBuV)	Limit (dBuV)	Margin (dB)	Detector (P/Q/A)
x.xx	62.95	0.55	63.50	87	-23.50	Q

- Freq. = Emission frequency in MHz
- Reading = Uncorrected Analyzer/Receiver reading
- Factor = Insertion loss of LISN + Cable Loss + Pulse Limit
- Result = Reading + Factor
- Limit = Limit stated in standard
- Margin = Reading in reference to limit
- P = Peak Reading
- Q = Quasi-peak Reading
- A = Average Reading

Calculation Formula

Margin (dB) = Result (dBuV) – Limit (dBuV)

7.2.6. TEST RESULTS

Model No.	eBOX700-891-FL	6dB Bandwidth	9 kHz
Environmental Conditions	21°C, 49% RH	Test Mode	Mode 4
Tested by	Bonny Tsai	Standard	EN 55032 CLASS A

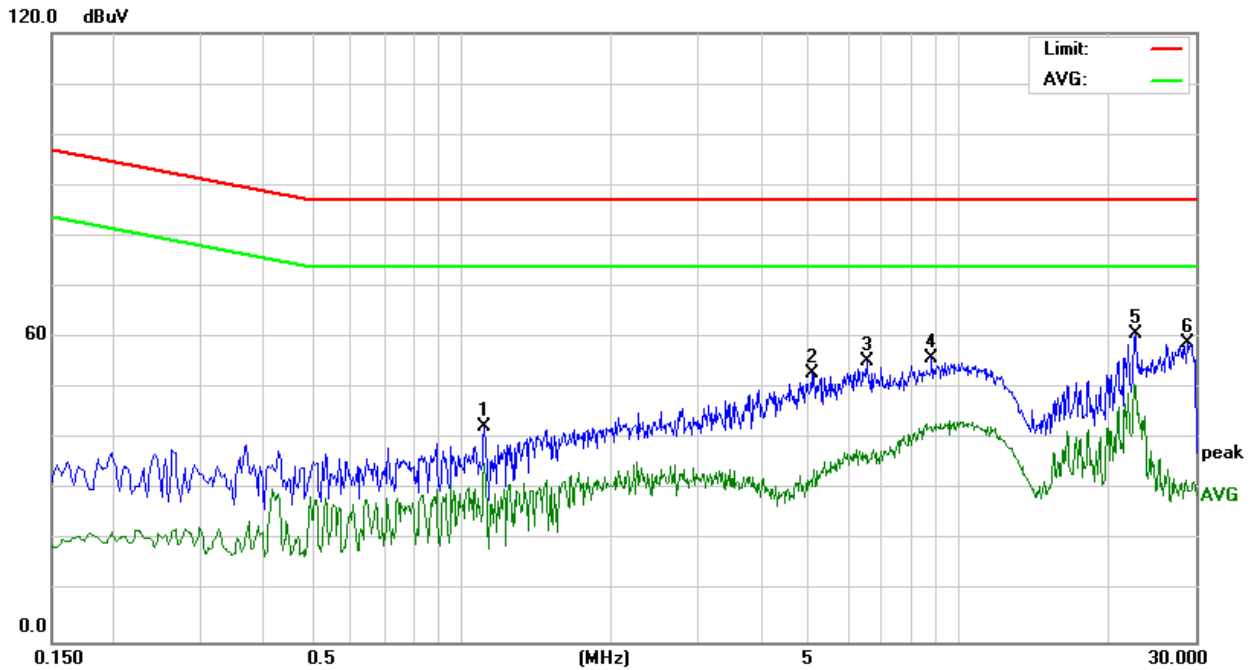

Conducted Emission Readings						
Frequency Range Investigated				150 kHz to 30 MHz		
Freq. (MHz)	Reading (dBuV)	Factor (dB)	Result (dBuV)	Limit (dBuV)	Margin (dB)	Detector (P/Q/A)
1.1140	22.83	19.61	42.44	87.00	-44.56	P
5.0699	33.24	19.66	52.90	87.00	-34.10	P
6.5379	35.58	19.67	55.25	87.00	-31.75	P
8.8619	36.27	19.69	55.96	87.00	-31.04	P
22.6580	40.80	20.10	60.90	87.00	-26.10	P
28.7980	38.48	20.38	58.86	87.00	-28.14	P

7.3. RADIATED EMISSION MEASUREMENT

7.3.1. LIMITS

Below 1GHz

FREQUENCY (MHz)	dBuV/m (At 10m)		dBuV/m (At 3m)	
	Class A	Class B	Class A	Class B
30 ~ 230	40	30	50	40
230 ~ 1000	47	37	57	47

Above 1GHz

Frequency (MHz)	Class A (dBuV/m) (At 3m)		Class B (dBuV/m) (At 3m)	
	Average	Peak	Average	Peak
1000 ~ 3000	56	76	50	70
3000 ~ 6000	60	80	54	74

NOTE: The lower limit shall apply at the transition frequencies.

According to EN 55032: 2015 / AC: 2016 Table 1 the measurement frequency range shown in the following table:

Table 1 – Required highest frequency for radiated measurement

Highest internal frequency (F_x)	Highest internal frequency
$F_x \leq 108$ MHz	1 GHz
108 MHz < $F_x \leq 500$ MHz	2 GHz
500 MHz < $F_x \leq 1$ GHz	5 GHz
$F_x > 1$ GHz	$5 \times F_x$ up to a maximum of 6 GHz
NOTE 1 For FM and TV broadcast receivers, F_x is determined from the highest frequency generated or used excluding the local oscillator and tuned frequencies.	
NOTE 2 F_x is defined in 3.1.19.	

Where F_x is unknown, the radiated emission measurements shall be performed up to 6 GHz.

Radiated emissions from FM receivers

Frequency range MHz	Measurement		Class B limit dB(μV/m)	
	Distance m	Detector type / bandwidth	Fundamental	Harmonics
			OATS / SAC (see Table A.1)	OATS / SAC (see Table A.1)
30 – 230	10	Quasi peak/ 120kHz	50	42
230 – 300				42
300 – 1000				46
30 – 230	3		60	52
230 – 300				52
300 – 1000				56

These relaxed limits apply only to emissions at the fundamental and harmonic frequencies of the local oscillator. Signals at all other frequencies shall be compliant with the limits given in 7.3.1 Class B Limit

7.3.2. TEST INSTRUMENTS

Open Area Test Site # H				
Name of Equipment	Manufacturer	Model	Serial Number	Calibration Due
Bilog Antenna	Teseq	CBL 6112D	36995	06/27/2018
Cable	EMEC	CFD400NL-LW	N-Type#H11	08/17/2018
EMI Test Receiver	R&S	ESCI	101340	03/28/2018
Pre-Amplifier	HP	8447D	1937A01554	09/28/2018
Thermo-Hygro Meter	Wisewind	201A	No. 03	06/04/2018
Test S/W	EZ-EMC			
Above 1GHz Used				
Horn Antenna	EMCO	3115	00022256	08/09/2018
K-Type Cable	Rosnol	K1K50-UP0264-K1k 50-1000	170803-1	08/22/2018
Microflex Cable	Rosnol	N1K50-EW0630-N1 k50-7000	170803-1	08/22/2018
Pre-Amplifier	Com-Power	PAM-118A	551041	06/27/2018
Signal Analyzer	R&S	FSV40	101269	04/23/2018
Test S/W	EZ-EMC			

NOTE: 1. The calibration interval of the above test instruments is 12 months and the calibrations are traceable to NML/ROC and NIST/USA.
 2. N.C.R = No Calibration Request.

7.3.3. TEST PROCEDURE (please refer to measurement standard or CCS SOP PA-031 & PA-041)**Procedure of Preliminary Test**

- The equipment was set up as per the test configuration to simulate typical usage per the user's manual. When the EUT is a tabletop system, a wooden turntable with a height of 0.8 meters is used which is placed on the ground plane. When the EUT is a floor standing equipment, it is placed on the ground plane which has a 15 cm non-conductive covering to insulate the EUT from the ground plane.
- Support equipment, if needed, was placed as per EN 55032.
- All I/O cables were positioned to simulate typical usage as per EN 55032.
- The EUT received AC power source from the outlet socket under the turntable. All support equipment power received from another socket under the turntable.
- The antenna was placed at 10 meter away from the EUT as stated in EN 55032. The antenna connected to the Spectrum Analyzer via a cable and at times a pre-amplifier would be used.
- The Analyzer / Receiver quickly scanned from 30MHz to 6000MHz. The EUT test program was started. Emissions were scanned and measured rotating the EUT to 360 degrees and positioning the antenna 1 to 4 meters above the ground plane, in both the vertical and the horizontal polarization, to maximize the emission reading level.
- The test mode(s) described in Item 4.1 were scanned during the preliminary test:
- After the preliminary scan, we found the test mode described in Item 4.1 producing the highest emission level.
- The EUT and cable configuration, antenna position, polarization and turntable position of the above highest emission level were recorded for the final test.

Procedure of Final Test

- EUT and support equipment were set up on the turntable as per the configuration with highest emission level in the preliminary test.
- The Analyzer / Receiver scanned from 30MHz to 6000MHz. Emissions were scanned and measured rotating the EUT to 360 degrees, varying cable placement and positioning the antenna 1 to 4 meters above the ground plane, in both the vertical and the horizontal polarization, to maximize the emission reading level.
- Recorded at least the six highest emissions. Emission frequency, amplitude, antenna position, polarization and turntable position were recorded into a computer in which correction factors were used to calculate the emission level and compare reading to the applicable limit. Below 1GHz the Q.P. reading and above 1GHz the Peak and Average reading are presented.
- The test data of the worst-case condition(s) was recorded.

7.3.4. TEST SETUP

Below 1GHz

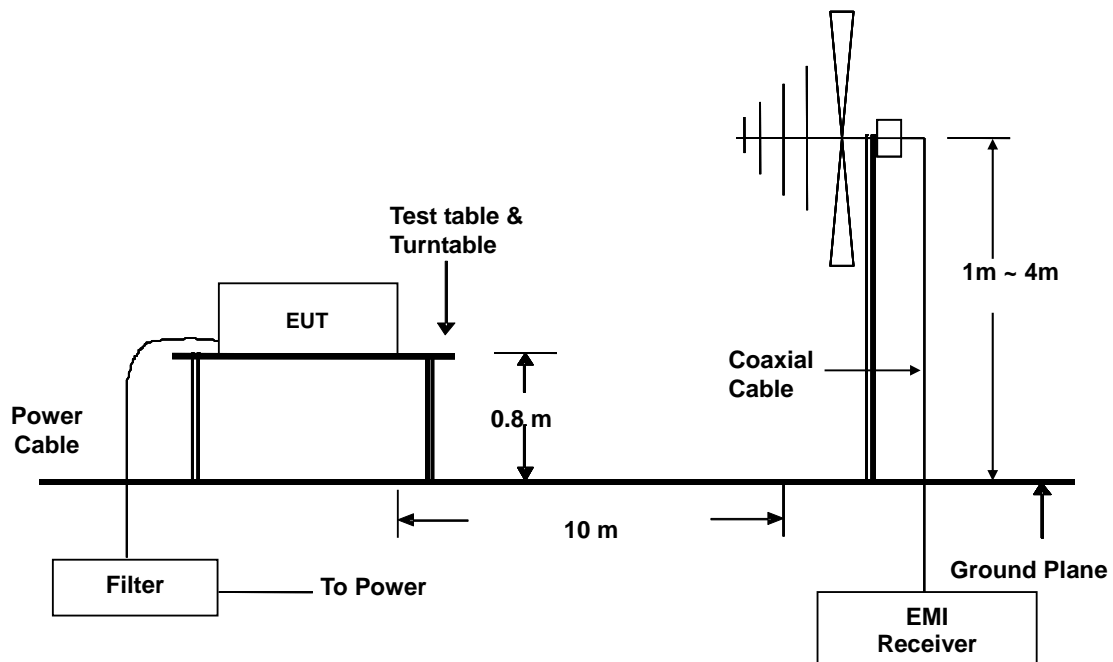

Above 1GHz

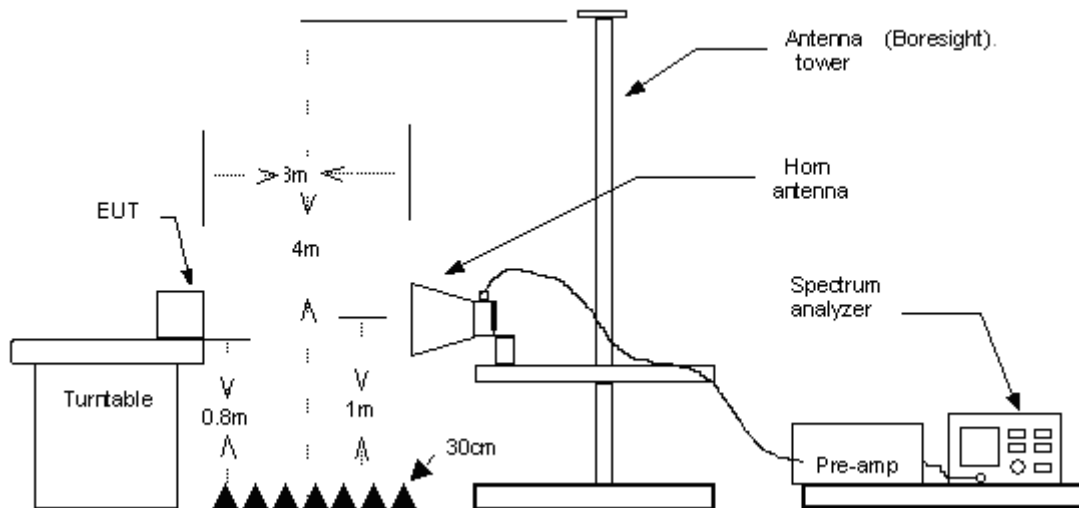

- For the actual test configuration, please refer to the related item – Photographs of the Test Configuration.

7.3.5. DATA SAMPLE

Below 1GHz

Freq. (MHz)	Reading (dBuV)	Factor (dB/m)	Result (dBuV/m)	Limit (dBuV/m)	Margin (dB)	Detector (P/Q)	Pol. (H/V)
x.xx	14.0	12.2	26.2	40	-13.8	Q	H

Above 1GHz

Freq. (MHz)	Reading (dBuV)	Factor (dB/m)	Result (dBuV/m)	Limit (dBuV/m)	Margin (dB)	Detector (P/A)	Pol. (H/V)
x.xx	42.95	0.55	43.50	60	-16.50	A	H

- Freq. = Emission frequency in MHz
- Reading = Uncorrected Analyzer/Receiver reading
- Factor = Antenna Factor + Cable Loss - Amplifier Gain
- Result = Reading + Factor
- Limit = Limit stated in standard
- Margin = Reading in reference to limit
- P = Peak Reading
- Q = Quasi-peak Reading
- A = Average Reading
- H = Antenna Polarization: Horizontal
- V = Antenna Polarization: Vertical

Calculation Formula

Margin (dB) = Result (dBuV/m) – Limit (dBuV/m)

7.3.6. TEST RESULTS

Below 1GHz

Model No.	eBOX700-891-FL	Test Mode	Mode 2
Environmental Conditions	19°C, 68% RH	6dB Bandwidth	120 kHz
Antenna Pole	Vertical	Antenna Distance	10m
Detector Function	Quasi-peak.	Tested by	Bonny Tsai
Standard	EN 55032 CLASS A		

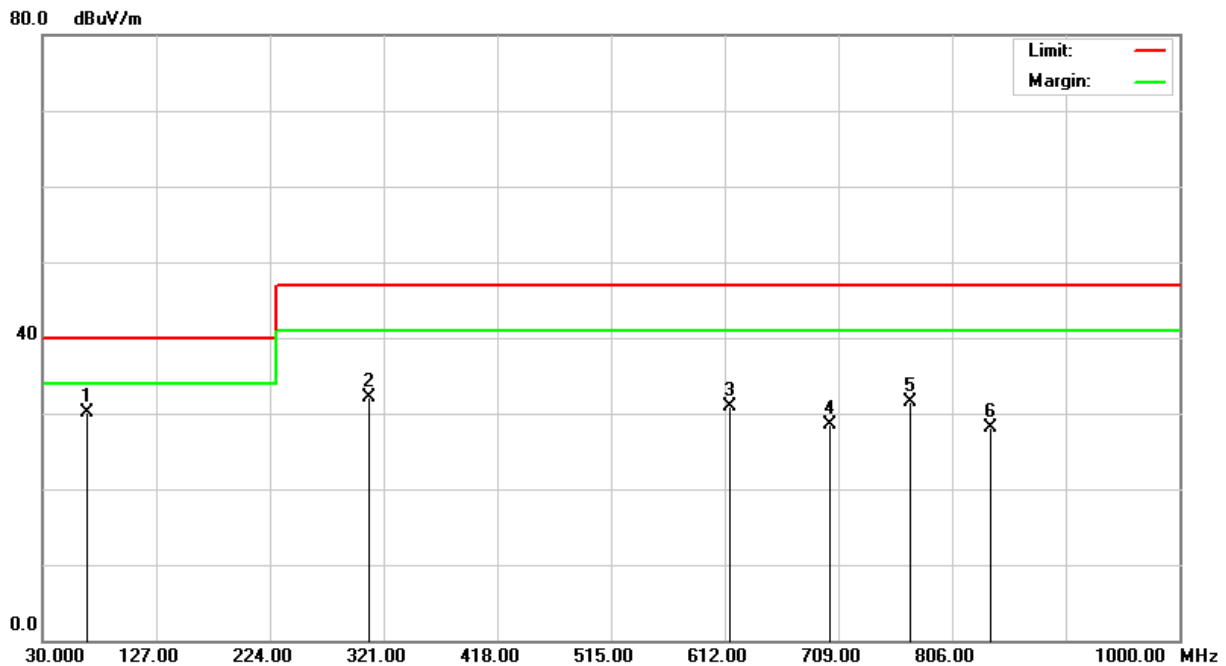

Radiated Emission Readings									
Frequency Range Investigated				30 MHz to 1000 MHz at 10m					
Freq. (MHz)	Reading (dBuV)	Factor (dB/m)	Result (dBuV/m)	Limit (dBuV/m)	Margin (dB)	Height (cm)	Degree (°)	Detector (P/Q)	Pol. (H/V)
68.1100	44.37	-14.34	30.03	40.00	-9.97	100	243	Q	V
308.1500	38.21	-6.06	32.15	47.00	-14.85	100	115	Q	V
616.0000	30.59	0.27	30.86	47.00	-16.14	400	201	Q	V
702.2400	27.55	0.89	28.44	47.00	-18.56	400	44	Q	V
770.0200	29.46	2.08	31.54	47.00	-15.46	400	349	Q	V
838.9600	25.30	2.73	28.03	47.00	-18.97	400	152	Q	V

Note: 1. P= Peak Reading; Q= Quasi-peak Reading.

Model No.	eBOX700-891-FL	Test Mode	Mode 2
Environmental Conditions	19°C, 68% RH	6dB Bandwidth	120 kHz
Antenna Pole	Horizontal	Antenna Distance	10m
Detector Function	Quasi-peak.	Tested by	Bonny Tsai
Standard	EN 55032 CLASS A		

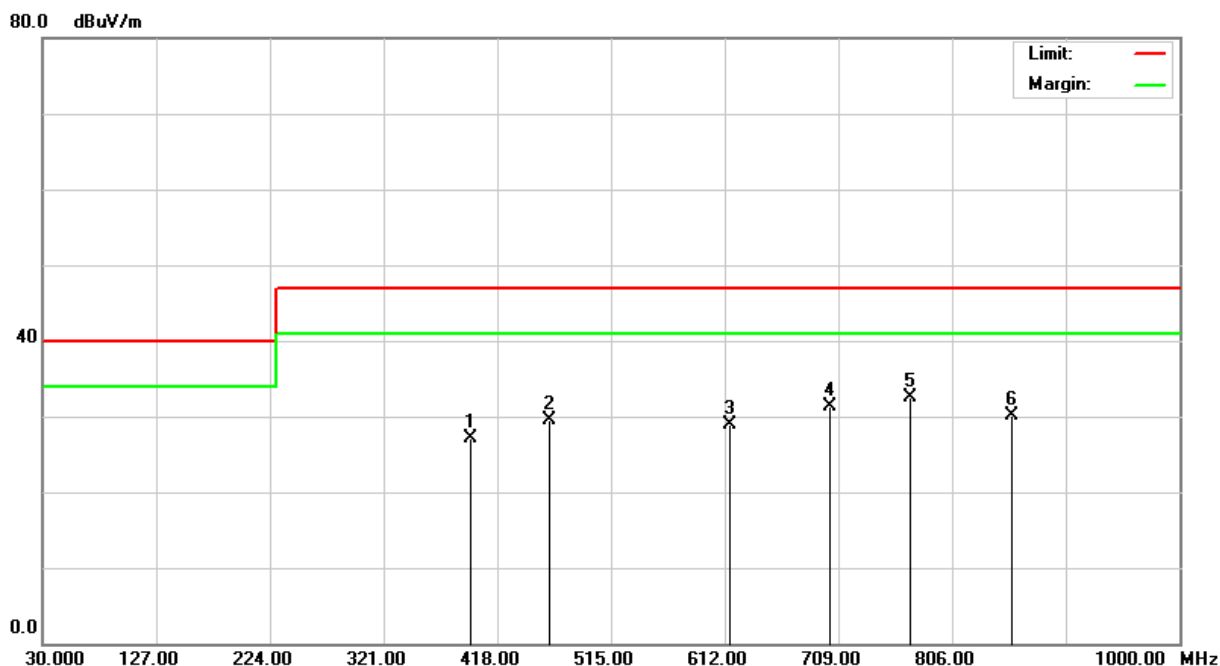

Radiated Emission Readings									
Frequency Range Investigated				30 MHz to 1000 MHz at 10m					
Freq. (MHz)	Reading (dBuV)	Factor (dB/m)	Result (dBuV/m)	Limit (dBuV/m)	Margin (dB)	Height (cm)	Degree (°)	Detector (P/Q)	Pol. (H/V)
395.5600	30.29	-3.26	27.03	47.00	-19.97	400	159	Q	H
462.0000	31.40	-1.91	29.49	47.00	-17.51	100	236	Q	H
616.0000	28.56	0.27	28.83	47.00	-18.17	100	80	Q	H
702.2300	30.33	0.89	31.22	47.00	-15.78	100	350	Q	H
770.0000	30.45	2.08	32.53	47.00	-14.47	100	206	Q	H
857.4200	27.10	2.92	30.02	47.00	-16.98	100	77	Q	H

Note: 1. P= Peak Reading; Q= Quasi-peak Reading.

Above 1GHz

Model No.	eBOX700-891-FL	Test Mode	Mode 2
Environmental Conditions	26°C, 60% RH	6dB Bandwidth	1 MHz
Antenna Pole	Vertical / Horizontal	Antenna Distance	3m
Highest frequency generated or used	3700MHz	Upper frequency	6000MHz
Detector Function	Peak and average.	Tested by	Bonny Tsai
Standard	EN 55032 CLASS A		

Radiated Emission Readings							
Frequency Range Investigated				Above 1GHz at 3m			
Freq. (MHz)	Reading (dBuV)	Factor (dB/m)	Result (dBuV/m)	Limit (dBuV/m)	Margin (dB)	Detector (P/A)	Pol. (H/V)
1135.000	61.29	-8.91	52.38	76.00	-23.62	P	V
1230.000	60.44	-8.74	51.70	76.00	-24.30	P	V
1495.000	58.57	-8.27	50.30	76.00	-25.70	P	V
1780.000	58.32	-6.41	51.91	76.00	-24.09	P	V
1945.000	59.92	-5.33	54.59	76.00	-21.41	P	V
2880.000	55.72	-4.19	51.53	76.00	-24.47	P	V

Radiated Emission Readings							
Frequency Range Investigated				Above 1GHz at 3m			
Freq. (MHz)	Reading (dBuV)	Factor (dB/m)	Result (dBuV/m)	Limit (dBuV/m)	Margin (dB)	Detector (P/A)	Pol. (H/V)
1010.000	58.74	-9.13	49.61	76.00	-26.39	P	H
1230.000	61.16	-8.74	52.42	76.00	-23.58	P	H
1450.000	57.62	-8.35	49.27	76.00	-26.73	P	H
1845.000	54.62	-5.98	48.64	76.00	-27.36	P	H
1940.000	54.43	-5.37	49.06	76.00	-26.94	P	H
2155.000	57.80	-4.78	53.02	76.00	-22.98	P	H

Note: 1. P= Peak Reading; A= Average Reading.

Radiated emissions from FM receivers

Model No.	N/A	Test Mode	N/A
Environmental Conditions	N/A	6dB Bandwidth	N/A
Antenna Pole	N/A	Antenna Distance	N/A
Detector Function	N/A	Tested by	N/A

Note: No applicable, the EUT doesn't have FM port.

7.4. CONDUCTED DIFFERENTIAL VOLTAGE EMISSIONS FROM CLASS B EQUIPMENT

Applicable to				
1. TV broadcast receiver tuner ports with an accessible connector				
2. RF modulator output ports				
3. FM broadcast receiver tuner ports with an accessible connector				
Frequency range MHz	Class B limits DB(μ V) 75 Ω			Applicability
	other	Local Oscillator Fundamental	Local Oscillator Harmonics	
30 – 950	46	46	46	See a)
950 – 2 150	46	54	54	
950 – 2 150	46	54	54	See b)
30 – 300	46	54	50	See c)
300 – 1 000			52	
30 – 300	46	66	59	See d)
300 – 1 000			52	
30 – 950	46	76	46	See e)
950 – 2 150		n/a	54	
a) Television receivers (analogue or digital), video recorders and PC TV broadcast receiver tuner cards working in channels between 30 MHz and 1 GHz, and digital audio receivers.				
b) Tuner units (not the LNB) for satellite signal reception.				
c) Frequency modulation audio receivers and PC tuner cards.				
d) Frequency modulation car radios.				
e) Applicable to EUTs with RF modulator output ports (for example DVD equipment, video recorders, camcorders and decoders etc.) designed to connect to TV broadcast receiver tuner ports.				
Testing is required at only one EUT supply voltage and frequency.				
The term 'other' refers to all emissions other than the fundamental and the harmonics of the local oscillator.				
The test shall be performed with the device operating at each reception channel.				
The test shall cover the entire frequency range.				

7.4.1. TEST PROCEDURES (please refer to measurement standard or CCS SOP PA-041)**Procedure of Preliminary Test**

- The equipment was set up as per the test configuration to simulate typical usage per the user's manual. The EUT was placed on a wooden table with a height of 0.8 meters was used that was placed on the ground plane.
- Support equipment, if needed, was placed as per EN 55032.
- All I/O cables were positioned to simulate typical usage as per EN 55032.
- The EUT received AC power source, from the outlet socket. All support equipment received power was from another socket.
- Added a $75 \longleftrightarrow 50 \Omega$ matching network, between EUT and EMI test receiver to get impedance match condition during the test.
- The output level of the auxiliary signal generator shall be set to give the value of 60 dB (μV) for FM receiver or 70 dB (μV) for TV and VCR to the input of the frequency-modulation or television receiver (or video recorder) respectively, on a 75Ω impedance. An additional amplifier should be inserted at the generator output, if necessary.
- The output level of the auxiliary signal generator shall be a standard TV color bar Move signal for TV receivers and video recorders with sound carrier that defined in Table A12 of EN 55032. An additional amplifier should be inserted at the generator output, if necessary.
- The results shall be expressed in the terms of the substitution voltage in decibels (μV), as supplied by the standard signal generator. The specified source impedance of the receiver shall be stated with the results.
- When measurements are made at the antenna terminals of the EUT, an auxiliary signal generator shall be used to feed the equipment under test input with a standard test signal (see Table A.12 of CISPR 32/ EN 55032) at the receiver tuning frequency (30MHz to 2150MHz).
- The test mode(s) described in Item 4.1 were scanned during the preliminary test:
- After the preliminary scan, we found the test mode described in Item 4.1 producing the highest emission level.
- The EUT and cable configuration of the above highest emission levels were recorded for the final test.

Procedure of Final Test

- EUT and support equipment were set up on the table as per the configuration with highest emission level in the preliminary test.
- The Analyzer / Receiver scanned from 30MHz to 2150MHz. recorded the value, the local frequency, amplitude, were recorded in which correction factors were used to calculate the emission level and compare reading to the applicable limit, and only Q.P reading will record in this report.
- Recorded at least the six highest emissions. Emission frequencies, amplitude were recorded into a computer in which correction factors were used to calculate the emission level and compare reading to the applicable limit and only Q.P. reading is presented.
- The test data of the worst-case condition(s) was recorded.

7.4.2. DATA SAMPLE

Freq. (MHz)	Matching Factor (dB)	Spectrum Reading (dBuV)	SG Level (dBuV)	Emission (dBuV)	Limit Line (dBuV)	Over Limit (dB)	Note (F/H/O)
x.xx	12.2	14.0	38.4	26.2	46	-19.8	F

- Freq. = Emission frequency in MHz
- Matching Factor = Matching network(50/75Ω) attenuation
- Spectrum Reading= Spectrum analyzer reading
- S.G. Level = Standard S.G. output level
- Emission = SG Level - Matching Factor
- Limit Line = Limit stated in standard
- Over Limit = Reading in reference to limit
- F = Fundamental
- H = Harmonics
- O = Other

Calculation Formula

Over Limit (dB) = Emission (dBμV) – Limit Line (dBμV)

7.4.3. TEST RESULTS

Model No.	N/A	6dB Bandwidth	N/A
Environmental Conditions	N/A	Test Mode	N/A
Tested by	N/A		

Note: No applicable, the EUT doesn't have tuner port.

7.5. HARMONICS CURRENT MEASUREMENT

7.5.1. LIMITS OF HARMONICS CURRENT MEASUREMENT

Limits for Class A equipment		Limits for Class D equipment		
Harmonics Order n	Max. permissible harmonics current A	Harmonics Order n	Max. permissible harmonics current per watt mA/W	Max. permissible harmonics current A
Odd harmonics		Odd Harmonics only		
3	2.30	3	3.4	2.30
5	1.14	5	1.9	1.14
7	0.77	7	1.0	0.77
9	0.40	9	0.5	0.40
11	0.33	11	0.35	0.33
13	0.21	13	0.30	0.21
15<=n<=39	0.15x15/n	15<=n<=39	3.85/n	0.15x15/n
Even harmonics				
2	1.08			
4	0.43			
6	0.30			
8<=n<=40	0.23x8/n			

- NOTE:** 1. Class A and Class D are classified according to item 7.5.3.
 2. According to section 7 of EN 61000-3-2, the above limits for all equipment except for lighting equipment having an active input power > 75 W and no limits apply for equipment with an active input power up to and including 75 W.

7.5.2. TEST INSTRUMENTS

Name of Equipment	Manufacturer	Model	Serial Number	Calibration Due
5kVA Power Source	Teseq	5001IX-208-TSQ	1537A01296	11/02/2018
H/F Measurement System	EMC Partner	HAR1000-1P	189	11/02/2018
Software	HARCS V4.19			

- NOTE:** The calibration interval of the above test instruments is 12 months and the calibrations are traceable to NML/ROC and NIST/USA.

7.5.3. TEST PROCEDURE (please refer to measurement standard or CCS SOP PA-029)

- The EUT was placed on the top of a wooden table 0.8 meters above the ground and operated to produce the maximum harmonic components under normal operating conditions for each successive harmonic component in turn.
- The classification of EUT is according to section 5 of EN 61000-3-2.
- The EUT is classified as follows:

Class A: Balanced three-phase equipment, Household appliances excluding equipment as Class D, Tools excluding portable tools, Dimmers for incandescent lamps, audio equipment, equipment not specified in one of the three other classes.

Class B: Portable tools; Arc welding equipment which is not professional equipment.

Class C: Lighting equipment.

Class D: Equipment having a specified power less than or equal to 600 W of the following types: Personal computers and personal computer monitors; television receivers and refrigerators and freezers having one or more variable-speed drives to control compressor motor(s).

- The correspondent test program of test instrument to measure the current harmonics emanated from EUT is chosen. The measure time shall be not less than the time necessary for the EUT to be exercised.

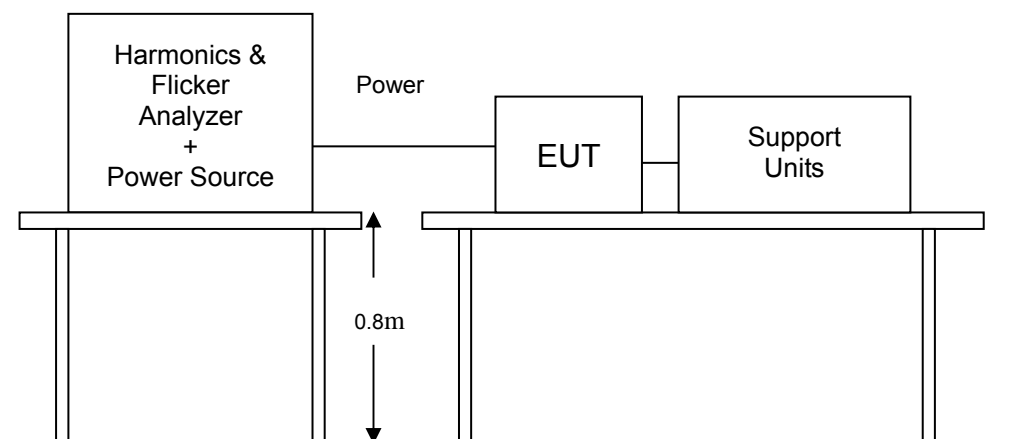
7.5.4. TEST SETUP

- For the actual test configuration, please refer to the related item – Photographs of the Test Configuration.

7.5.5. TEST RESULTS

Power Consumption	53.01W	Test Results	PASS
Environmental Conditions	22°C, 53% RH, 1009mbar	Tested by	Class <input checked="" type="checkbox"/> A <input type="checkbox"/> B <input type="checkbox"/> C <input type="checkbox"/> D
Test Mode	Operating	Tested by	David Cheng

NOTE: 1. Limits classified according to item 7.5.1.

Test result of EN 61000-3-2

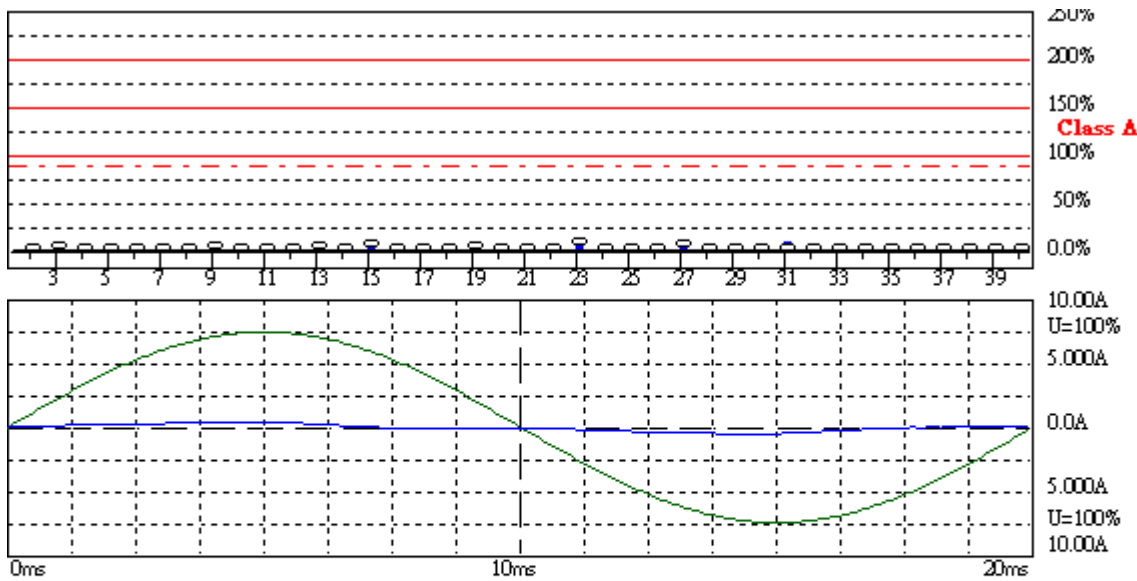

Harmonic Emission - IEC 61000-3-2, EN 61000-3-2, (EN60555-2)

2017/12/29 10:08:50

U_{rms} = 229.9 V P = 53.01 W THC = 0.091 A
 I_{rms} = 0.264 A pf = 0.874

Range: 10 A
 V_{nom}: 230 V
 TestTime: 30 min (100%)

Test completed, Result: PASSED

BAR-1000 EMC-Tester

Urms = 229.9V Freq = 50.013 Range: 10 A
 Irms = 0.264A Ipk = 0.522A cf = 1.981
 P = 53.01W S = 60.62VA pf = 0.874
 THDi = 36.6 % THDu = 0.10 % Class A

Test - Time : 30min (100 %)

Test completed, Result: PASSED

Order	Freq. [Hz]	Iavg [A]	Irms [A]	Irms% [%]	Irms%L [%]	I _{max} [A]	I _{max} % [%]	I _{max} %L [%]	Limit [A]	Status
1	50	0.2496	0.2496	94.676		0.2942	111.57			
2	100	0.0049	0.0049	1.8519	0.4521	0.0067	2.5463	0.6217	1.0800	
3	150	0.0840	0.0836	31.713	3.6356	0.0989	37.500	4.2990	2.3000	
4	200	0.0000	0.0006	0.2315	0.1419	0.0012	0.4630	0.2839	0.4300	
5	250	0.0254	0.0250	9.4907	2.1951	0.0305	11.574	2.6770	1.1400	
6	300	0.0000	0.0006	0.2315	0.2035	0.0006	0.2315	0.2035	0.3000	
7	350	0.0130	0.0128	4.8611	1.6646	0.0165	6.2500	2.1402	0.7700	
8	400	0.0000	0.0006	0.2315	0.2654	0.0006	0.2315	0.2654	0.2300	
9	450	0.0123	0.0122	4.6296	3.0518	0.0146	5.5556	3.6621	0.4000	
10	500	0.0000	0.0006	0.2315	0.3317	0.0006	0.2315	0.3317	0.1840	
11	550	0.0072	0.0073	2.7778	2.2195	0.0085	3.2407	2.5894	0.3300	
12	600	0.0000	0.0006	0.2315	0.3981	0.0006	0.2315	0.3981	0.1533	
13	650	0.0055	0.0055	2.0833	2.6158	0.0067	2.5463	3.1971	0.2100	
14	700	0.0000	0.0006	0.2315	0.4644	0.0006	0.2315	0.4644	0.1314	
15	750	0.0067	0.0067	2.5463	4.4759	0.0079	3.0093	5.2897	0.1500	
16	800	0.0000	0.0006	0.2315	0.5307	0.0006	0.2315	0.5307	0.1150	
17	850	0.0000	0.0031	1.1574	2.3058	0.0037	1.3889	2.7669	0.1324	
18	900	0.0000	0.0006	0.2315	0.5971	0.0006	0.2315	0.5971	0.1022	
19	950	0.0051	0.0049	1.8519	4.1233	0.0067	2.5463	5.6695	0.1184	
20	1000	0.0000	0.0006	0.2315	0.6634	0.0012	0.4630	1.3269	0.0920	
21	1050	0.0006	0.0043	1.6204	3.9876	0.0055	2.0833	5.1270	0.1071	
22	1100	0.0000	0.0012	0.4630	1.4595	0.0012	0.4630	1.4595	0.0836	
23	1150	0.0060	0.0061	2.3148	6.2391	0.0061	2.3148	6.2391	0.0978	
24	1200	0.0000	0.0006	0.2315	0.7961	0.0012	0.4630	1.5922	0.0767	
25	1250	0.0000	0.0006	0.2315	0.6782	0.0012	0.4630	1.3563	0.0900	
26	1300	0.0000	0.0006	0.2315	0.8625	0.0006	0.2315	0.8625	0.0708	
27	1350	0.0049	0.0049	1.8519	5.8594	0.0061	2.3148	7.3242	0.0833	
28	1400	0.0000	0.0006	0.2315	0.9288	0.0006	0.2315	0.9288	0.0657	
29	1450	0.0000	0.0031	1.1574	3.9334	0.0037	1.3889	4.7201	0.0776	
30	1500	0.0000	0.0006	0.2315	0.9951	0.0006	0.2315	0.9951	0.0613	
31	1550	0.0000	0.0043	1.6204	5.8865	0.0043	1.6204	5.8865	0.0726	
32	1600	0.0000	0.0006	0.2315	1.0615	0.0006	0.2315	1.0615	0.0575	
33	1650	0.0000	0.0012	0.4630	1.7904	0.0018	0.6944	2.6855	0.0682	
34	1700	0.0000	0.0006	0.2315	1.1278	0.0006	0.2315	1.1278	0.0541	
35	1750	0.0000	0.0031	1.1574	4.7472	0.0037	1.3889	5.6966	0.0643	
36	1800	0.0000	0.0006	0.2315	1.1942	0.0006	0.2315	1.1942	0.0511	
37	1850	0.0000	0.0024	0.9259	4.0148	0.0031	1.1574	5.0184	0.0608	
38	1900	0.0000	0.0006	0.2315	1.2605	0.0006	0.2315	1.2605	0.0484	
39	1950	0.0000	0.0024	0.9259	4.2318	0.0031	1.1574	5.2897	0.0577	
40	2000	0.0000	0.0006	0.2315	1.3269	0.0006	0.2315	1.3269	0.0460	

Definitions of Abbreviations

Urms	***	Actual total Voltage in Volt RMS
Irms	***	Actual total Current in Ampere RMS
Ipk	***	Actual Peak value of the Current in Ampere
cf	***	Actual Crest Factor (Ipk/Irms)
P	***	Actual Active Power in Watt
S	***	Actual Apparent Power in VA (Urms*Irms)
pf	***	Actual Power Factor (P/S)
THDi	***	Actual Total Harmonic Current Distortion in %
THDu	***	Actual Total Harmonic Voltage Distortion in %
THC	***	Actual Total Harmonic Current in Ampere
PHC	***	Actual Partial Harmonic Current in Ampere

Individual measurements for 2nd to 40th order:

lavg		Average value of the Individual Harmonic Current in Ampere RMS
Irms	***	Actual Individual Harmonic Current in Ampere RMS
Irms%	***	Actual Individual Harmonic Current in percentage of the actual total RMS Current
Irms%L	***	Actual Individual Harmonic Current in percentage of the applicable Limit
Imax		Maximum Individual Harmonic Current in Ampere RMS
Imax%		Maximum Individual Harmonic Current in percentage of the actual total RMS Current
Imax%lim		Maximum Individual Harmonic Current in percentage of the applicable Limit
Limit Irms		Individual Limit (100%) for the selected Class in Ampere RMS

7.6. VOLTAGE FLUCTUATION AND FLICKER MEASUREMENT

7.6.1. LIMITS OF VOLTAGE FLUCTUATION AND FLICKER MEASUREMENT

TEST ITEM	LIMIT	REMARK
P_{st}	1.0	P_{st} means short-term flicker indicator.
P_{lt}	0.65	P_{lt} means long-term flicker indicator.
T_{dt} (ms)	500	T_{dt} means maximum time that dt exceeds 3 %.
d_{max} (%)	4%	d_{max} means maximum relative voltage change.
dc (%)	3.3%	dc means relative steady-state voltage change

7.6.2. TEST INSTRUMENTS

Name of Equipment	Manufacturer	Model	Serial Number	Calibration Due
5kVA Power Source	Teseq	5001IX-208-TSQ	1537A01296	11/02/2018
H/F Measurement System	EMC Partner	HAR1000-1P	189	11/02/2018
Software	HARCS V4.19			

NOTE: The calibration interval of the above test instruments is 12 months and the calibrations are traceable to NML/ROC and NIST/USA.

7.6.3. TEST PROCEDURE (please refer to measurement standard or CCS SOP PA-030)

- The EUT was placed on the top of a wooden table 0.8 meters above the ground and operated to produce the most unfavorable sequence of voltage changes under normal operating conditions.
- During the flick measurement, the measure time shall include that part of whole operation cycle in which the EUT produce the most unfavorable sequence of voltage changes. The observation period for short-term flicker indicator is 10 minutes and the observation period for long-term flicker indicator is 2 hours.

7.6.4. TEST SETUP

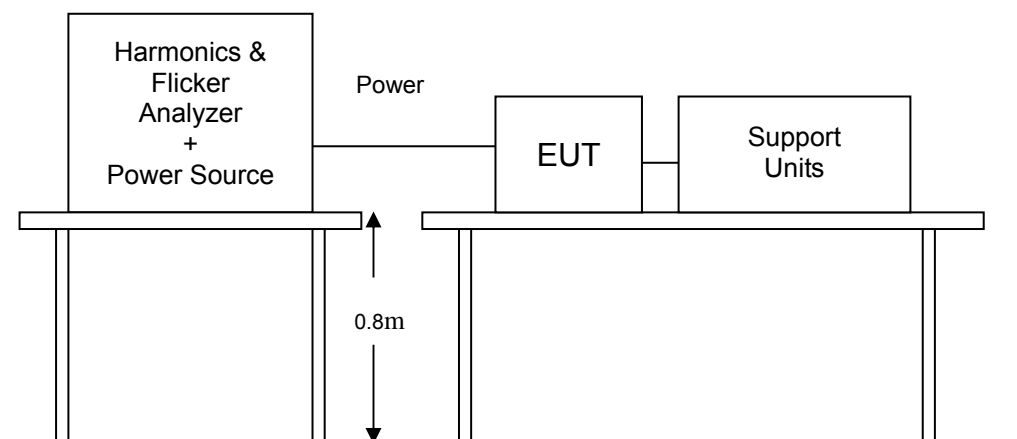

- For the actual test configuration, please refer to the related item – Photographs of the Test Configuration.

7.6.5. TEST RESULTS

Observation Period (Tp)	30mins	Test Mode	Operating
Environmental Conditions	22°C, 53% RH, 1009mbar	Tested by	David Cheng

TEST PARAMETER	MEASUREMENT VALUE	LIMIT	REMARK
P _{st}	0.07	1.0	PASS
P _{lt}	0.07	0.65	PASS
T _{dt} (ms)	0.00	500	PASS
d _{max} (%)	0.00	4%	PASS
dc (%)	0.01	3.3%	PASS

Note: None.

Test result of EN 61000-3-3

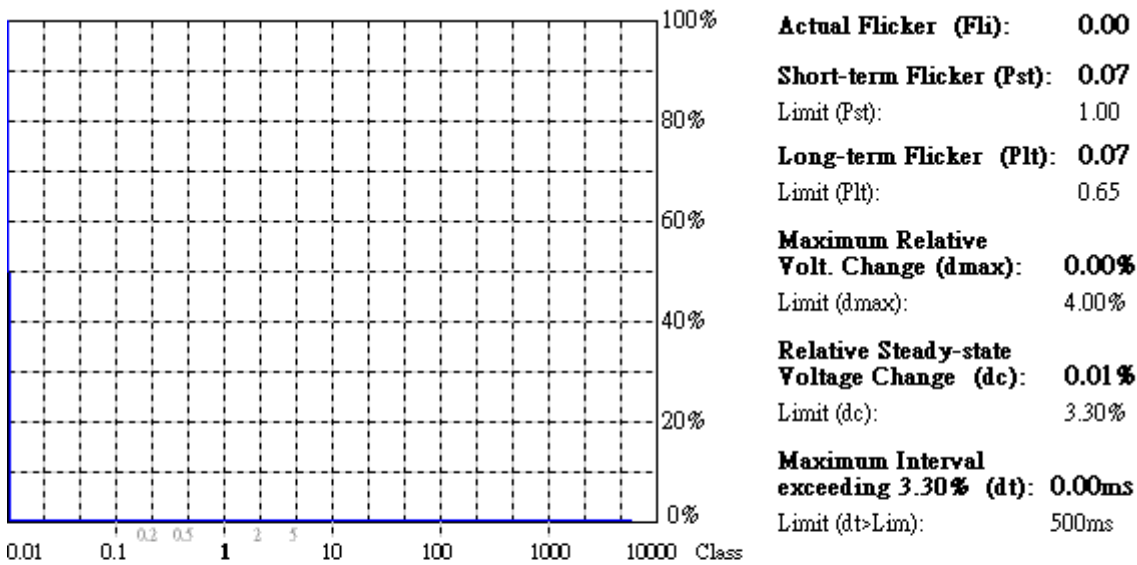

Flicker Emission - IEC 61000-3-3 , EN 61000-3-3

2017/12/29 10:53:33

U_{rms} = 229.7 V P = 51.78 W
 I_{rms} = 0.259 A pf = 0.871

Range: 10 A
 V_{nom}: 230 V
 TestTime: 30 min (100%)

Test completed, Result: PASSED

BAR-1000 EMC-Retec

8 IMMUNITY TEST

8.1. GENERAL DESCRIPTION

Product Standard	EN 55024: 2010 + A1: 2015	
	Test Type	Minimum Requirement
Basic Standard, Specification, and Performance Criterion required	IEC 61000-4-2	Electrostatic Discharge - ESD: 8kV air discharge, 4kV Contact discharge, Performance Criterion B
	IEC 61000-4-3	Radio-Frequency Electromagnetic Field Susceptibility Test - RS: 80 ~1000 MHz, 3V/m, 80% AM(1kHz), Performance Criterion A
	IEC 61000-4-4	Electrical Fast Transient/Burst - EFT, AC Power Port: 1kV DC Power Port: 0.5kV Signal Ports and Telecommunication Ports: 0.5kV Performance Criterion B
	IEC 61000-4-5	Surge Immunity Test: 1.2/50 μ s Open Circuit Voltage, 8/20 μ s Short Circuit Current, AC Power Port ~ line to line: 1kV, line to ground: 2kV DC Power Port ~ line to ground: 0.5kV Signal Ports and Telecommunication Ports ~ line to ground: 1kV Performance Criterion B 10/700 μ s Open Circuit Voltage, Performance Criterion C
	IEC 61000-4-6	Conducted Radio Frequency Disturbances Test - CS: 0.15 ~ 80 MHz, 3Vrms, 80% AM, 1kHz, Performance Criterion A
	IEC 61000-4-8	Power frequency magnetic field immunity test 50 Hz or 60 Hz, 1A/m, Performance Criterion A
	IEC 61000-4-11	Voltage Dips: i) >95% reduction for 0.5 period, Performance Criterion B ii) 30% reduction for 25 period, Performance Criterion C Voltage Interruptions: >95% reduction for 250 period Performance Criterion C

8.2. GENERAL PERFORMANCE CRITERIA DESCRIPTION

<p>Criteria A:</p>	<p>The apparatus shell continues to operate as intended without operator intervention. No degradation of performance or loss of function is allowed below a performance level specified by the manufacturer, when the apparatus is used as intended. The performance level may be replaced by a permissible loss of performance. If the manufacturer does not specify the minimum performance level or the permissible performance loss, then either of these may be derived from the product description and documentation, and by what the user may reasonably expect from the equipment if used as intended.</p>
<p>Criteria B:</p>	<p>After test, the apparatus shell continues to operate as intended without operator intervention. No degradation of performance or loss of function is allowed, after the application of the phenomenon below a performance level specified by the manufacturer, when the apparatus is used as intended. The performance level may be replaced by a permissible loss of performance.</p> <p>During the test, degradation of performance is however allowed. However, no change of operating state if stored data is allowed to persist after the test. If the manufacturer does not specify the minimum performance level or the permissible performance loss, then either of these may be derived from the product description and documentation, and by what the user may reasonably expect from the equipment if used as intended.</p>
<p>Criteria C:</p>	<p>Temporary loss of function is allowed, provided the functions is self-recoverable or can be restored by the operation of controls by the user in accordance with the manufacturer instructions.</p> <p>Functions, and/or information stored in non-volatile memory, or protected by a battery backup, shall not be lost.</p>

8.3. ELECTROSTATIC DISCHARGE (ESD)

8.3.1. TEST SPECIFICATION

Basic Standard:	IEC 61000-4-2
Discharge Impedance:	330 ohm / 150 pF
Discharge Voltage:	Air Discharge: 2 ; 4 ; 8 kV (Direct) Contact Discharge: 2 ; 4 kV (Direct/Indirect)
Polarity:	Positive & Negative
Number of Discharge:	Air Discharge: min. 10 times at each test point for each polarity Contact Discharge: min. 200 times in total
Discharge Mode:	Single Discharge 1 second minimum

8.3.2. TEST INSTRUMENT

IMMUNITY SHIELDED ROOM				
Name of Equipment	Manufacturer	Model	Serial Number	Calibration Due
Aneroid Barometer	SATO	7610-20	89090	09/25/2018
ESD Simulator	Teseq	NSG 437	1189	10/05/2018
Thermo-Hygro Meter	Wisewind	N/A	SD-S017	10/01/2018

NOTE: The calibration interval of the above test instruments is 12 months and the calibrations are traceable to NML/ROC and NIST/USA.

8.3.3. TEST PROCEDURE (please refer to measurement standard or CCS SOP PA-022)

The discharges shall be applied in two ways:

a) Contact discharges to the conductive surfaces and coupling planes:

The EUT shall be exposed to at least 200 discharges, 100 each at negative and positive polarity, at a minimum of four test points. One of the test points shall be subjected to at least 50 indirect discharges to the center of the front edge of the **Horizontal Coupling Plane (HCP)**. The remaining three test points shall each receive at least 50 direct contact discharges. If no direct contact test points are available, then at least 200 indirect discharges shall be applied in the indirect mode. Test shall be performed at a maximum repetition rate of one discharge per second.

b) Air discharges at slots and apertures and insulating surfaces:

On those parts of the EUT where it is not possible to perform contact discharge testing, the equipment should be investigated to identify user accessible points where breakdown may occur. Such points are tested using the air discharge method. This investigation should be restricted to those area normally handled by the user. A minimum of 10 single air discharges shall be applied to the selected test point for each such area.

The basic test procedure was in accordance with IEC 61000-4-2:

- a) The EUT was located 0.1 m minimum from all side of the **HCP** (dimensions 1.6m x 0.8m).
- b) The support units were located another table 30 cm away from the EUT, but direct support unit was/were located at same location as EUT on the HCP and keep at a distance of 10 cm with EUT.
- c) The time interval between two successive single discharges was at least 1 second.
- d) Contact discharges were applied to the non-insulating coating, with the pointed tip of the generator penetrating the coating and contacting the conducting substrate.
- e) Air discharges were applied with the round discharge tip of the discharge electrode approaching the EUT as fast as possible (without causing mechanical damage) to touch the EUT. After each discharge, the ESD generator was removed from the EUT and re-triggered for a new single discharge. The test was repeated until all discharges were complete.
- f) At least ten single discharges (in the most sensitive polarity) were applied at the front edge of each **HCP** opposite the center point of each unit of the EUT and 0.1 meters from the front of the EUT. The long axis of the discharge electrode was in the plane of the **HCP** and perpendicular to its front edge during the discharge.
- g) At least ten single discharges (in the most sensitive polarity) were applied to the center of one vertical edge of the **Vertical Coupling Plane (VCP)** in sufficiently different positions that the four faces of the EUT were completely illuminated. The **VCP** (dimensions 0.5m x 0.5m) was placed vertically to and 0.1 meters from the EUT.

8.3.4. TEST SETUP

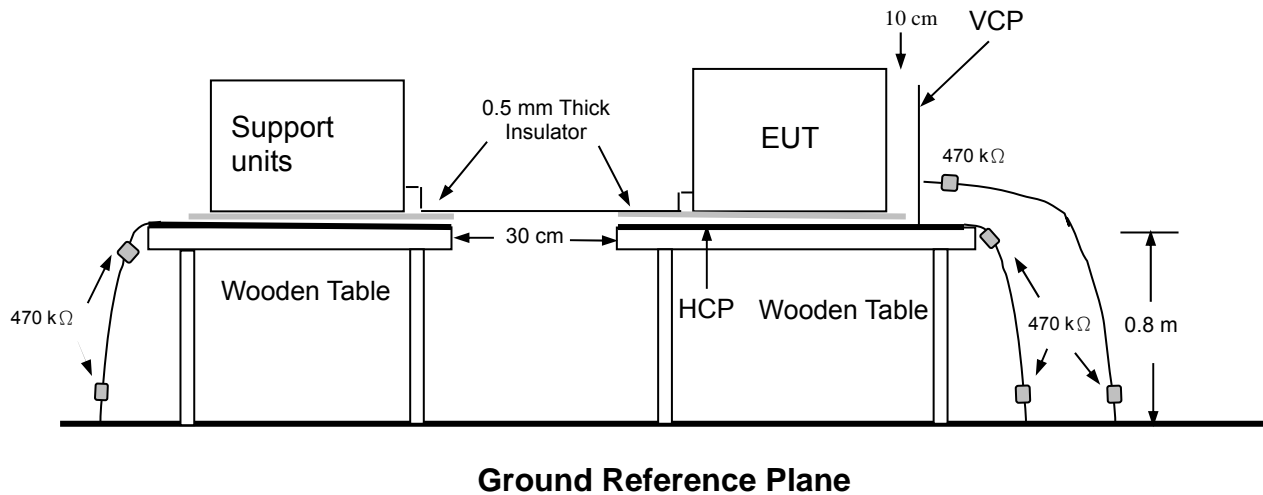

- For the actual test configuration, please refer to the related item – Photographs of the Test Configuration.

NOTE:

TABLE-TOP EQUIPMENT

The configuration consisted of a wooden table 0.8 meters high standing on the **Ground Reference Plane**. The **GRP** consisted of a sheet of aluminum at least 0.25mm thick, and 2.5 meters square connected to the protective grounding system. A **Horizontal Coupling Plane** (1.6m x 0.8m) was placed on the table and attached to the **GRP** by means of a cable with 940k total impedance. The equipment under test, was installed in a representative system as described in section 7 of IEC 61000-4-2, and its cables were placed on the **HCP** and isolated by an insulating support of 0.5mm thickness. A distance of 1-meter minimum was provided between the EUT and the walls of the laboratory and any other metallic structure.

FLOOR-STANDING EQUIPMENT

The equipment under test was installed in a representative system as described in section 7 of IEC 61000-4-2, and its cables were isolated from the Ground Reference Plane by an insulating support of 0.1-meter thickness. The GRP consisted of a sheet of aluminum that is at least 0.25mm thick, and 2.5 meters square connected to the protective grounding system and extended at least 0.5 meters from the EUT on all sides.

8.3.5. TEST RESULTS

Temperature	20°C	Humidity	50% RH
Pressure	1009mbar	Tested By	David Cheng
Required Passing Performance		Criterion B	

Air Discharge									
Test Points	Test Levels					Results			
	± 2 kV	± 4 kV	± 8 kV	± 12 kV	± 15 kV	Pass	Fail	Performance Criterion	Observation
Front	<input checked="" type="checkbox"/>	<input checked="" type="checkbox"/>	<input checked="" type="checkbox"/>	<input type="checkbox"/>	<input type="checkbox"/>	<input checked="" type="checkbox"/>	<input type="checkbox"/>	<input checked="" type="checkbox"/> A <input type="checkbox"/> B	Note <input type="checkbox"/> 1 <input checked="" type="checkbox"/> 2
Back	<input checked="" type="checkbox"/>	<input checked="" type="checkbox"/>	<input checked="" type="checkbox"/>	<input type="checkbox"/>	<input type="checkbox"/>	<input checked="" type="checkbox"/>	<input type="checkbox"/>	<input checked="" type="checkbox"/> A <input type="checkbox"/> B	Note <input type="checkbox"/> 1 <input checked="" type="checkbox"/> 2

Contact Discharge									
Test Points	Test Levels				Results				
	± 2 kV	± 4 kV	± 6 kV	± 8 kV	Pass	Fail	Performance Criterion	Observation	
Front	<input checked="" type="checkbox"/>	<input checked="" type="checkbox"/>	<input type="checkbox"/>	<input type="checkbox"/>	<input checked="" type="checkbox"/>	<input type="checkbox"/>	<input checked="" type="checkbox"/> A <input type="checkbox"/> B	Note <input checked="" type="checkbox"/> 1 <input type="checkbox"/> 2	
Back	<input checked="" type="checkbox"/>	<input checked="" type="checkbox"/>	<input type="checkbox"/>	<input type="checkbox"/>	<input checked="" type="checkbox"/>	<input type="checkbox"/>	<input checked="" type="checkbox"/> A <input type="checkbox"/> B	Note <input checked="" type="checkbox"/> 1 <input type="checkbox"/> 2	
Left	<input checked="" type="checkbox"/>	<input checked="" type="checkbox"/>	<input type="checkbox"/>	<input type="checkbox"/>	<input checked="" type="checkbox"/>	<input type="checkbox"/>	<input checked="" type="checkbox"/> A <input type="checkbox"/> B	Note <input checked="" type="checkbox"/> 1 <input type="checkbox"/> 2	
Right	<input checked="" type="checkbox"/>	<input checked="" type="checkbox"/>	<input type="checkbox"/>	<input type="checkbox"/>	<input checked="" type="checkbox"/>	<input type="checkbox"/>	<input checked="" type="checkbox"/> A <input type="checkbox"/> B	Note <input checked="" type="checkbox"/> 1 <input type="checkbox"/> 2	
Top	<input checked="" type="checkbox"/>	<input checked="" type="checkbox"/>	<input type="checkbox"/>	<input type="checkbox"/>	<input checked="" type="checkbox"/>	<input type="checkbox"/>	<input checked="" type="checkbox"/> A <input type="checkbox"/> B	Note <input checked="" type="checkbox"/> 1 <input type="checkbox"/> 2	

Discharge To Horizontal Coupling Plane									
Side of EUT	Test Levels				Results				
	± 2 kV	± 4 kV	± 6 kV	± 8 kV	Pass	Fail	Performance Criterion	Observation	
Front	<input checked="" type="checkbox"/>	<input checked="" type="checkbox"/>	<input type="checkbox"/>	<input type="checkbox"/>	<input checked="" type="checkbox"/>	<input type="checkbox"/>	<input checked="" type="checkbox"/> A <input type="checkbox"/> B	Note <input checked="" type="checkbox"/> 1 <input type="checkbox"/> 2	
Back	<input checked="" type="checkbox"/>	<input checked="" type="checkbox"/>	<input type="checkbox"/>	<input type="checkbox"/>	<input checked="" type="checkbox"/>	<input type="checkbox"/>	<input checked="" type="checkbox"/> A <input type="checkbox"/> B	Note <input checked="" type="checkbox"/> 1 <input type="checkbox"/> 2	
Left	<input checked="" type="checkbox"/>	<input checked="" type="checkbox"/>	<input type="checkbox"/>	<input type="checkbox"/>	<input checked="" type="checkbox"/>	<input type="checkbox"/>	<input checked="" type="checkbox"/> A <input type="checkbox"/> B	Note <input checked="" type="checkbox"/> 1 <input type="checkbox"/> 2	
Right	<input checked="" type="checkbox"/>	<input checked="" type="checkbox"/>	<input type="checkbox"/>	<input type="checkbox"/>	<input checked="" type="checkbox"/>	<input type="checkbox"/>	<input checked="" type="checkbox"/> A <input type="checkbox"/> B	Note <input checked="" type="checkbox"/> 1 <input type="checkbox"/> 2	

Discharge To Vertical Coupling Plane									
Side of EUT	Test Levels				Results				
	± 2 kV	± 4 kV	± 6 kV	± 8 kV	Pass	Fail	Performance Criterion	Observation	
Front	<input checked="" type="checkbox"/>	<input checked="" type="checkbox"/>	<input type="checkbox"/>	<input type="checkbox"/>	<input checked="" type="checkbox"/>	<input type="checkbox"/>	<input checked="" type="checkbox"/> A <input type="checkbox"/> B	Note <input checked="" type="checkbox"/> 1 <input type="checkbox"/> 2	
Back	<input checked="" type="checkbox"/>	<input checked="" type="checkbox"/>	<input type="checkbox"/>	<input type="checkbox"/>	<input checked="" type="checkbox"/>	<input type="checkbox"/>	<input checked="" type="checkbox"/> A <input type="checkbox"/> B	Note <input checked="" type="checkbox"/> 1 <input type="checkbox"/> 2	
Left	<input checked="" type="checkbox"/>	<input checked="" type="checkbox"/>	<input type="checkbox"/>	<input type="checkbox"/>	<input checked="" type="checkbox"/>	<input type="checkbox"/>	<input checked="" type="checkbox"/> A <input type="checkbox"/> B	Note <input checked="" type="checkbox"/> 1 <input type="checkbox"/> 2	
Right	<input checked="" type="checkbox"/>	<input checked="" type="checkbox"/>	<input type="checkbox"/>	<input type="checkbox"/>	<input checked="" type="checkbox"/>	<input type="checkbox"/>	<input checked="" type="checkbox"/> A <input type="checkbox"/> B	Note <input checked="" type="checkbox"/> 1 <input type="checkbox"/> 2	

NOTE: 1. There was no change compared with initial operation during the test.
 2. No discharge point.

The Photo for Discharge Points of EUT
Front



Back

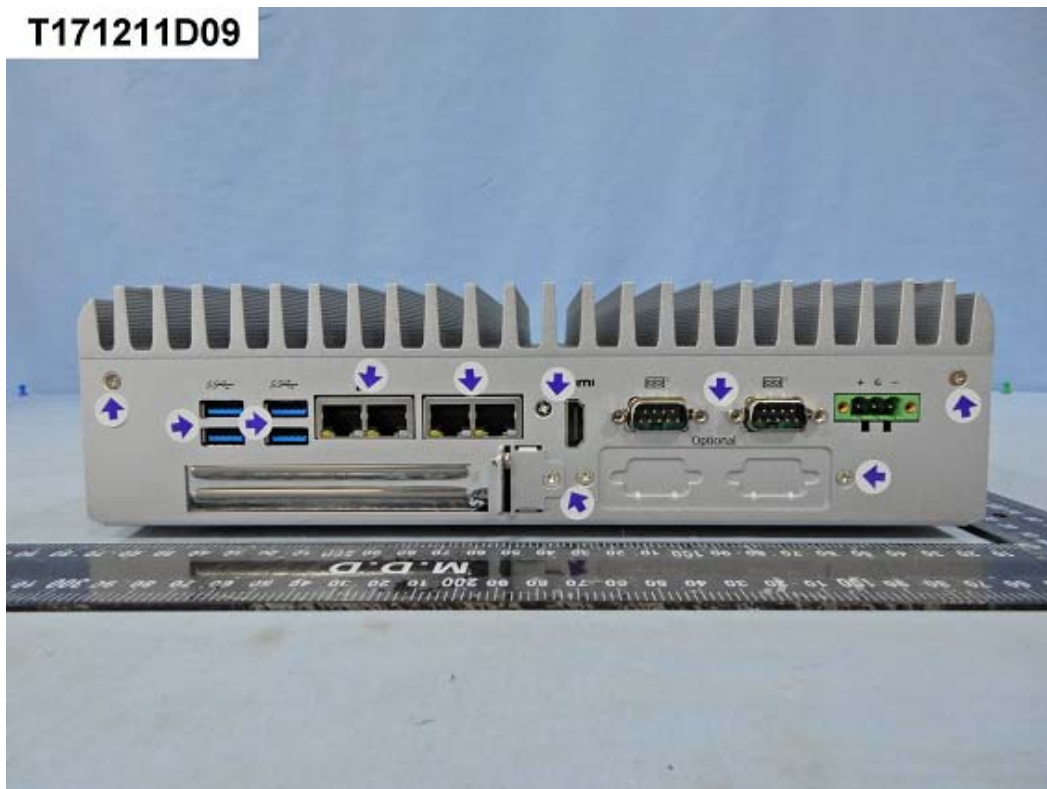

Red Dot —Air Discharged
Blue Dot —Contact Discharged

Left

T171211D09



Right

T171211D09



Red Dot —Air Discharged
Blue Dot —Contact Discharged

Top

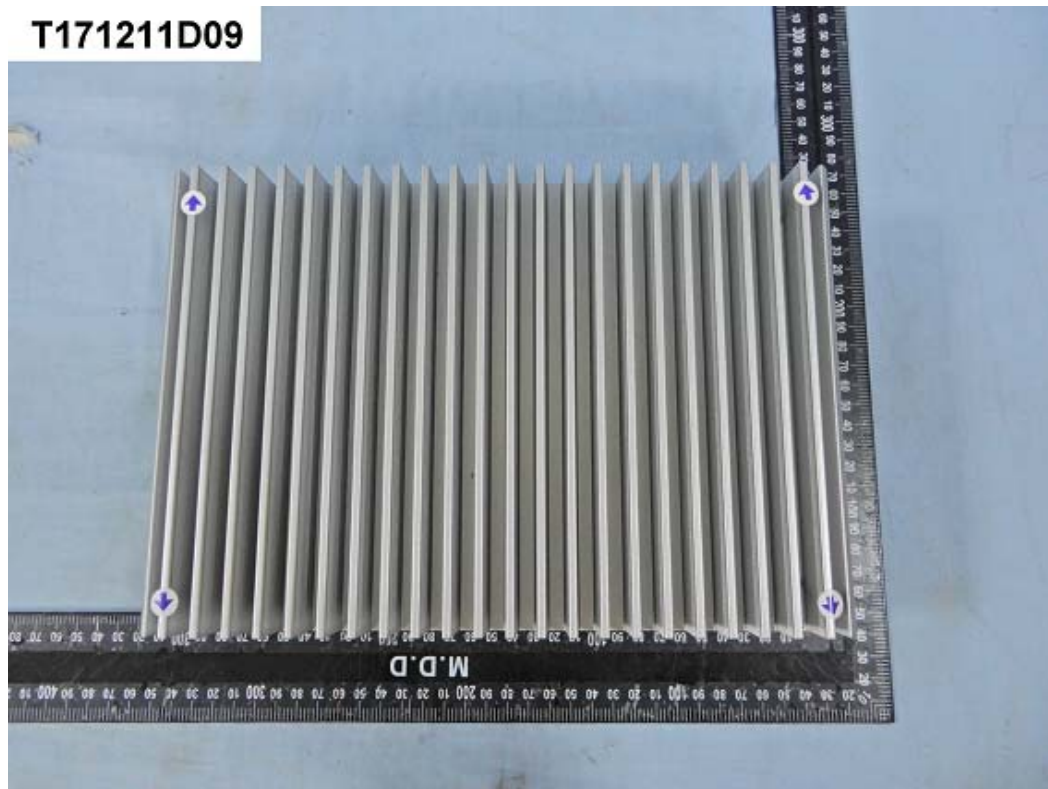

Red Dot —Air Discharged
Blue Dot —Contact Discharged

8.4. RADIATED, RADIO-FREQUENCY, ELECTROMAGNETIC FIELD (RS)

8.4.1. TEST SPECIFICATION

Basic Standard:	IEC 61000-4-3
Frequency Range:	80 MHz ~1000 MHz
Field Strength:	3 V/m
Modulation:	1kHz Sine Wave, 80%, AM Modulation
Frequency Step:	1 % of preceding frequency value
Polarity of Antenna:	Horizontal and Vertical
Test Distance:	3 m
Antenna Height:	1.5m

8.4.2. TEST INSTRUMENT

844 RS Chamber				
Name of Equipment	Manufacturer	Model	Serial Number	Calibration Due
Electric Field Probe	AR	FL7006	0338955	05/23/2018
Field of Calibration	CCS	Chamber#RS	80-1000MHz	05/07/2018
Power Sensor	Boonton	51013-4E	35811	02/13/2018
Power Sensor	Boonton	51013-4E	35812	02/13/2018
RF Power Meter	Boonton	4242-01-02	14357	02/13/2018
Thermo-Hygro Meter	Wisewind	N/A	SD-S018	10/01/2018
Broadband Antenna	AR	AT1080	311819	N.C.R
Power Amplifier	Milmega	80RF1000-600	1079361	N.C.R
Signal Generator	Agilent	N5181A	MY47421336	11/23/2018
Software	Emcware Ver. 2.6.0.16			

- NOTE:** 1. The calibration interval of the above test instruments is 12 months and the calibrations are traceable to NML/ROC and NIST/USA.
2. N.C.R.= No Calibration required

8.4.3. TEST PROCEDURE (please refer to measurement standard or CCS SOP PA-023)

The test procedure was in accordance with IEC 61000-4-3

- The testing was performed in a fully anechoic chamber. The transmit antenna was located at a distance of 3 meters from the EUT.
- The frequency range is swept from 80 MHz to 1000 MHz, with the signal 80% amplitude modulated with a 1kHz sine-wave. The rate of sweep did not exceed 1.5×10^{-3} decade/s, where the frequency range is swept incrementally, the step size was 1% of preceding frequency value.
- The dwell time at each frequency shall be not less than the time necessary for the EUT to be able to respond.
- The test was performed with the EUT exposed to both vertically and horizontally polarized fields on each of the four sides.

8.4.4. TEST SETUP

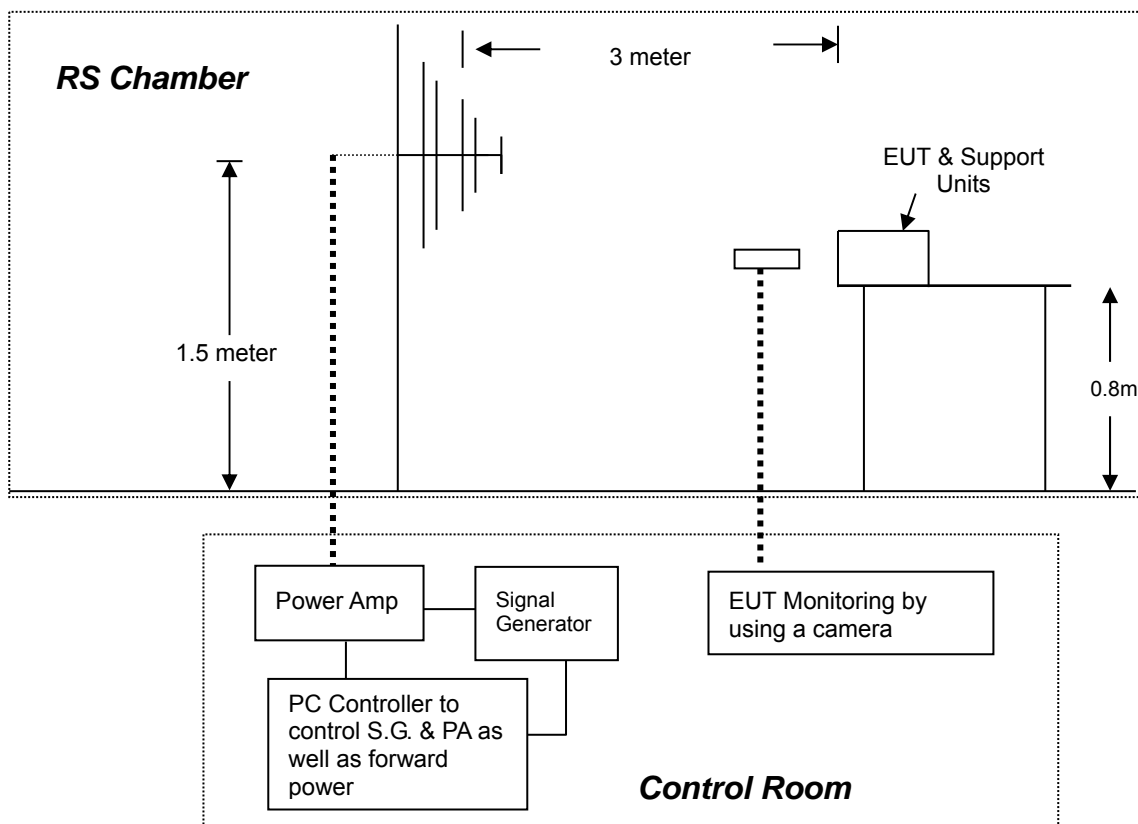

- For the actual test configuration, please refer to the related item – Photographs of the Test Configuration.

NOTE:

TABLETOP EQUIPMENT

The EUT installed in a representative system as described in section 7 of IEC 61000-4-3 was placed on a non-conductive table 0.8 meters in height. The system under test was connected to the power and signal wire according to relevant installation instructions.

FLOOR STANDING EQUIPMENT

The EUT installed in a representative system as described in section 7 of IEC 61000-4-3 was placed on a non-conductive wood support 0.1 meters in height. The system under test was connected to the power and signal wire according to relevant installation instructions.

8.4.5. TEST RESULTS

Temperature	21°C	Humidity	52% RH
Pressure	1009mbar	Dwell Time	3 sec.
Tested By	David Cheng	Required Passing Performance	Criterion A

Frequency (MHz)	Polarity	Azimuth	Field Strength (V/m)	Performance Criterion	Observation	Result
80 ~ 1000	V&H	0	3	<input checked="" type="checkbox"/> A <input type="checkbox"/> B	Note <input checked="" type="checkbox"/> 1 <input type="checkbox"/> 2	PASS
80 ~ 1000	V&H	90	3	<input checked="" type="checkbox"/> A <input type="checkbox"/> B	Note <input checked="" type="checkbox"/> 1 <input type="checkbox"/> 2	PASS
80 ~ 1000	V&H	180	3	<input checked="" type="checkbox"/> A <input type="checkbox"/> B	Note <input checked="" type="checkbox"/> 1 <input type="checkbox"/> 2	PASS
80 ~ 1000	V&H	270	3	<input checked="" type="checkbox"/> A <input type="checkbox"/> B	Note <input checked="" type="checkbox"/> 1 <input type="checkbox"/> 2	PASS

NOTE: 1. There was no change compared with the initial operation during the test.

8.5. ELECTRICAL FAST TRANSIENT (EFT)

8.5.1. TEST SPECIFICATION

Basic Standard:	IEC 61000-4-4
Test Voltage:	AC Power Port: 1kV Signal Ports and Telecommunication Ports: 0.5kV
Polarity:	Positive & Negative
Impulse Frequency:	5 kHz
Impulse Wave-shape:	5/50 ns
Burst Duration:	15 ms
Burst Period:	300 ms
Test Duration:	Not less than 1 min.

8.5.2. TEST INSTRUMENT

Immunity Shield Room				
Name of Equipment	Manufacturer	Model	Serial Number	Calibration Due
Capacitive Clamp	EMC-Partner	CN-EFT1000	589	07/17/2018
EMC Immunity Tester	EMC Partner	TRANSINT 2000	1117	03/07/2018
Software	GenecsVer. 3.27			

NOTE: 1. The calibration interval of the above test instruments is 12 months and the calibrations are traceable to NML/ROC and NIST/USA.
2. N.C.R.= No Calibration required.

8.5.3. TEST PROCEDURE (please refer to measurement standard or CCS SOP PA-024)

- a) All types of cables, including their length, and the interface port of the EUT to which they were connected.
- b) Both positive and negative polarity discharges were applied.
- c) The length of the “hot wire” from the coaxial output of the EFT generator to the terminals on the EUT should not exceed 0.5 meter.
- d) The duration time of each test sequential was 1 minute.
- e) The transient/burst waveform was in accordance with IEC 61000-4-4, 5/50ns.

8.5.4. TEST SETUP

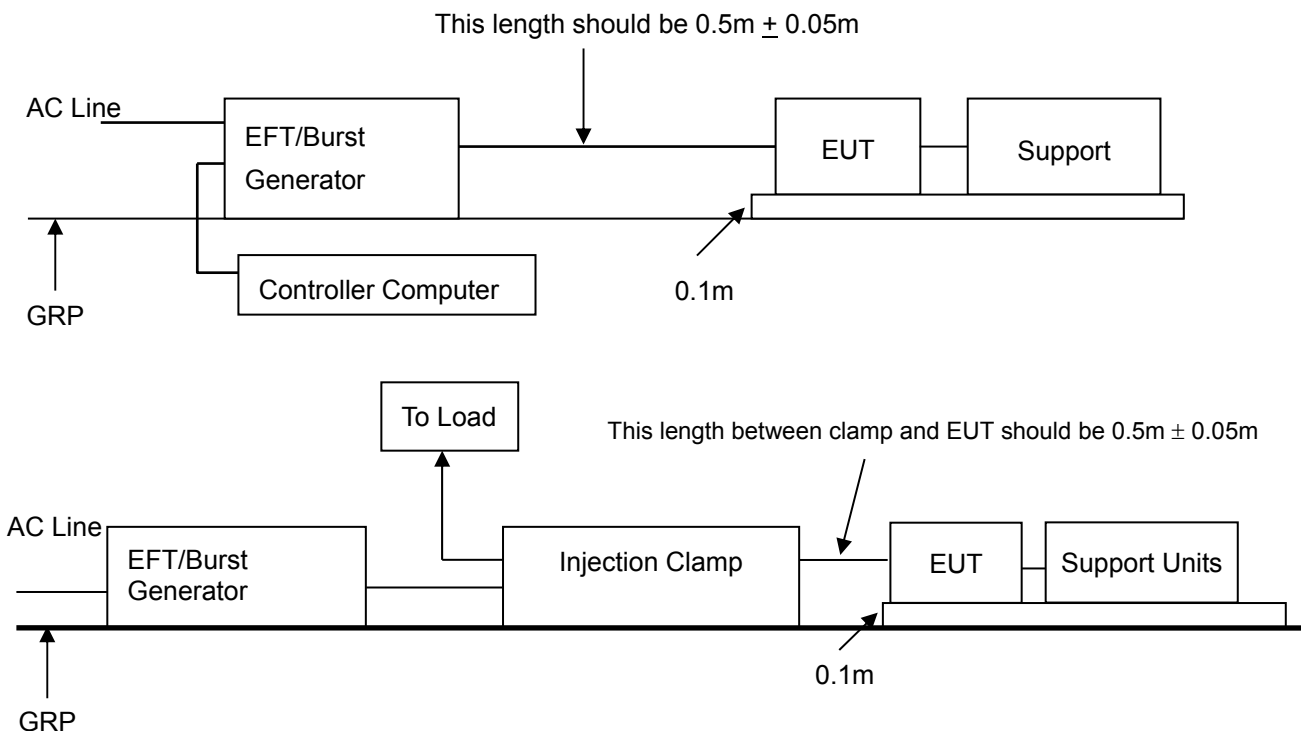

- For the actual test configuration, please refer to the related item – Photographs of the Test Configuration.

NOTE:

TABLETOP EQUIPMENT

The configuration consisted of a wooden table (0.1m high) standing on the Ground Reference Plane. The GRP consisted of a sheet of aluminum (at least 0.25mm thick and 2.5m square) connected to the protective grounding system. A minimum distance of 0.5m was provided between the EUT and the walls of the laboratory or any other metallic structure.

FLOOR STANDING EQUIPMENT

The EUT installed in a representative system as described in section 7 of IEC 61000-4-4 and its cables, were isolated from the Ground Reference Plane by an insulating support that is 0.1-meter thick. The GRP consisted of a sheet of aluminum (at least 0.25mm thick and 2.5m square) connected to the protective grounding system.

8.5.5. TEST RESULTS

Temperature	22°C	Humidity	53% RH
Pressure	1009mbar	Tested By	David Cheng
Required Passing Performance		Criterion B	

Test Point	Polarity	Test Level (kV)	Performance Criterion	Observation	Result
L	+/-	1	<input checked="" type="checkbox"/> A <input type="checkbox"/> B	Note <input checked="" type="checkbox"/> 1 <input type="checkbox"/> 2	PASS
N	+/-	1	<input checked="" type="checkbox"/> A <input type="checkbox"/> B	Note <input checked="" type="checkbox"/> 1 <input type="checkbox"/> 2	PASS
L - N	+/-	1	<input checked="" type="checkbox"/> A <input type="checkbox"/> B	Note <input checked="" type="checkbox"/> 1 <input type="checkbox"/> 2	PASS
PE	+/-	1	<input checked="" type="checkbox"/> A <input type="checkbox"/> B	Note <input checked="" type="checkbox"/> 1 <input type="checkbox"/> 2	PASS
L - PE	+/-	1	<input checked="" type="checkbox"/> A <input type="checkbox"/> B	Note <input checked="" type="checkbox"/> 1 <input type="checkbox"/> 2	PASS
N - PE	+/-	1	<input checked="" type="checkbox"/> A <input type="checkbox"/> B	Note <input checked="" type="checkbox"/> 1 <input type="checkbox"/> 2	PASS
L - N - PE	+/-	1	<input checked="" type="checkbox"/> A <input type="checkbox"/> B	Note <input checked="" type="checkbox"/> 1 <input type="checkbox"/> 2	PASS
RJ45	+/-	0.5	<input checked="" type="checkbox"/> A <input type="checkbox"/> B	Note <input checked="" type="checkbox"/> 1 <input type="checkbox"/> 2	PASS

NOTE: 1. There was no change compared with initial operation during the test.

8.6. SURGE IMMUNITY TEST

8.6.1. TEST SPECIFICATION

Basic Standard:	IEC 61000-4-5
Wave-Shape:	Combination Wave 1.2/50 μ s Open Circuit Voltage 8/20 μ s Short Circuit Current 10/700 μ s Open Circuit Voltage
Test Voltage:	AC Power Port~ line to line: 1kV, line to ground: 2kV Signal Ports and Telecommunication Ports ~ line to ground: 1kV
Surge Input/Output:	AC Power Line: L-N / L-PE / N-PE Signal Line: L-G
Generator Source Impedance:	2 ohm between networks 12 ohm between network and ground 42 ohm between network and ground
Polarity:	Positive/Negative
Phase Angle:	0° / 90° / 180° / 270°
Pulse Repetition Rate:	1 time / min. (maximum)
Number of Tests:	5 positive and 5 negative at selected points

8.6.2. TEST INSTRUMENT

Immunity Shield Room				
Name of Equipment	Manufacturer	Model	Serial Number	Calibration Due
CDN	EMC-Partner	CDN-UTP8	1505	02/22/2018
EMC Immunity Tester	EMC Partner	TRANSINT 2000	1117	03/07/2018
Software	GenecsVer. 3.27			

NOTE: 1. The calibration interval of the above test instruments is 12 months and the calibrations are traceable to NML/ROC and NIST/USA.
2. N.C.R.= No Calibration required

8.6.3. TEST PROCEDURE (please refer to measurement standard or CCS SOP PA-025)

- a) For EUT power supply:
The surge is applied to the EUT power supply terminals via the capacitive coupling network. Decoupling networks are required in order to avoid possible adverse effects on equipment not under test that may be powered by the same lines, and to provide sufficient decoupling impedance to the surge wave. The power cord between the EUT and the coupling/decoupling networks was shorter than 2 meters in length.
- b) For test applied to unshielded un-symmetrically operated interconnection lines of EUT:
The surge was applied to the lines via the capacitive coupling. The coupling / decoupling networks didn't influence the specified functional conditions of the EUT. The interconnection line between the EUT and the coupling/decoupling networks was shorter than 2 meters in length.
- c) For test applied to unshielded symmetrically operated interconnection / telecommunication lines of EUT:
The surge was applied to the lines via gas arrestors coupling. Test levels below the ignition point of the coupling arrestor were not specified. The interconnection line between the EUT and the coupling/decoupling networks was shorter than 2 meters in length.

8.6.4. TEST SETUP

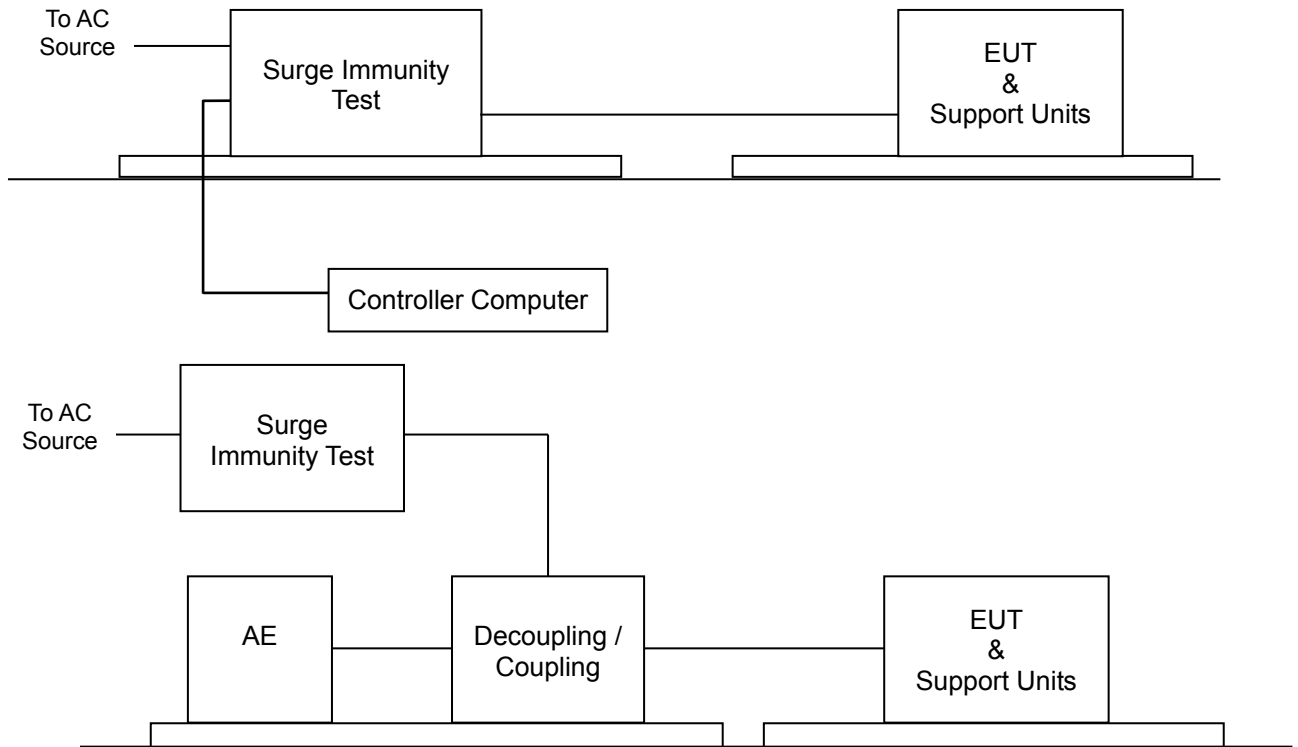

- For the actual test configuration, please refer to the related item - Photographs of the Test Configuration.

8.6.5. TEST RESULTS

Temperature	22°C	Humidity	53% RH
Pressure	1009mbar	Tested By	David Cheng
Required Passing Performance		Criterion B	

Test Point	Polarity	Test Level (kV)	Performance Criterion	Observation	Result
L - N	+/-	1	<input checked="" type="checkbox"/> A <input type="checkbox"/> B	Note <input checked="" type="checkbox"/> 1 <input type="checkbox"/> 2	PASS
L - PE	+/-	2	<input checked="" type="checkbox"/> A <input type="checkbox"/> B	Note <input checked="" type="checkbox"/> 1 <input type="checkbox"/> 2	PASS
N - PE	+/-	2	<input checked="" type="checkbox"/> A <input type="checkbox"/> B	Note <input checked="" type="checkbox"/> 1 <input type="checkbox"/> 2	PASS

NOTE: 1. There was no change compared with initial operation during the test.

Temperature	22°C	Humidity	53% RH
Pressure	1009mbar	Tested By	David Cheng
Required Passing Performance		Criterion C	

Test Point	Polarity	Test Level (kV)	Performance Criterion	Observation	Result
RJ45	+/-	1	<input checked="" type="checkbox"/> A <input type="checkbox"/> B <input type="checkbox"/> C	Note <input checked="" type="checkbox"/> 1 <input type="checkbox"/> 2	PASS

NOTE: 1. There was no change compared with initial operation during the test.

8.7. CONDUCTED RADIO FREQUENCY DISTURBANCES (CS)

8.7.1. TEST SPECIFICATION

Basic Standard:	IEC 61000-4-6
Frequency Range:	0.15 MHz ~ 80 MHz
Field Strength:	3 Vrms
Modulation:	1kHz Sine Wave, 80%, AM Modulation
Frequency Step:	1 % of preceding frequency value
Coupled cable:	Power Mains, Unshielded; RJ45 Line, Unshielded
Coupling device:	CDN-M3 (3 wires); CDN-T8

8.7.2. TEST INSTRUMENT

CS Room				
Name of Equipment	Manufacturer	Model	Serial Number	Calibration Due
Attenuator	EMCI	SA3NL	10006F	01/16/2018
CDN	Teseq	CDN M016	35820	02/13/2018
CDN	Teseq	CDN M016	35821	01/16/2018
CDN	Teseq	CDN T400A	25674	02/13/2018
CDN	Teseq	CDN T8-10	40369	02/14/2018
Continuous Wave Simulator	EM Test	CWS 500N1.4	P1446143188	02/13/2018
Software	icd.controlVer. 5.3.5			

- NOTE:** 1. The calibration interval of the above test instruments is 12 months and the calibrations are traceable to NML/ROC and NIST/USA.
 2. N.C.R.= No Calibration required.

8.7.3. TEST PROCEDURE (please refer to measurement standard or CCS SOP PA-026)

The EUT shall be tested within its intended operating and climatic conditions.

The test shall be performed with the test generator connected to each of the coupling and decoupling devices in turn, while the other non-excited RF input ports of the coupling devices are terminated by a 50-ohm load resistor.

The frequency range was swept from 150 kHz to 80 MHz, using the signal level established during the setting process and with a disturbance signal of 80 % amplitude. The signal was modulated with a 1 kHz sine wave, pausing to adjust the RF signal level or the switch coupling devices as necessary. The sweep rate was 1.5×10^{-3} decades/s. Where the frequency range is swept incrementally, the step size was 1 % of preceding frequency value from 150 kHz to 80 MHz.

The dwell time at each frequency was less than the time necessary for the EUT to be exercised, and able to respond. Sensitive frequencies such as clock frequency(ies) and harmonics or frequencies of dominant interest, was analyzed separately.

Attempts were made to fully exercise the EUT during testing, and to fully interrogate all exercise modes selected for susceptibility.

8.7.4. TEST SETUP

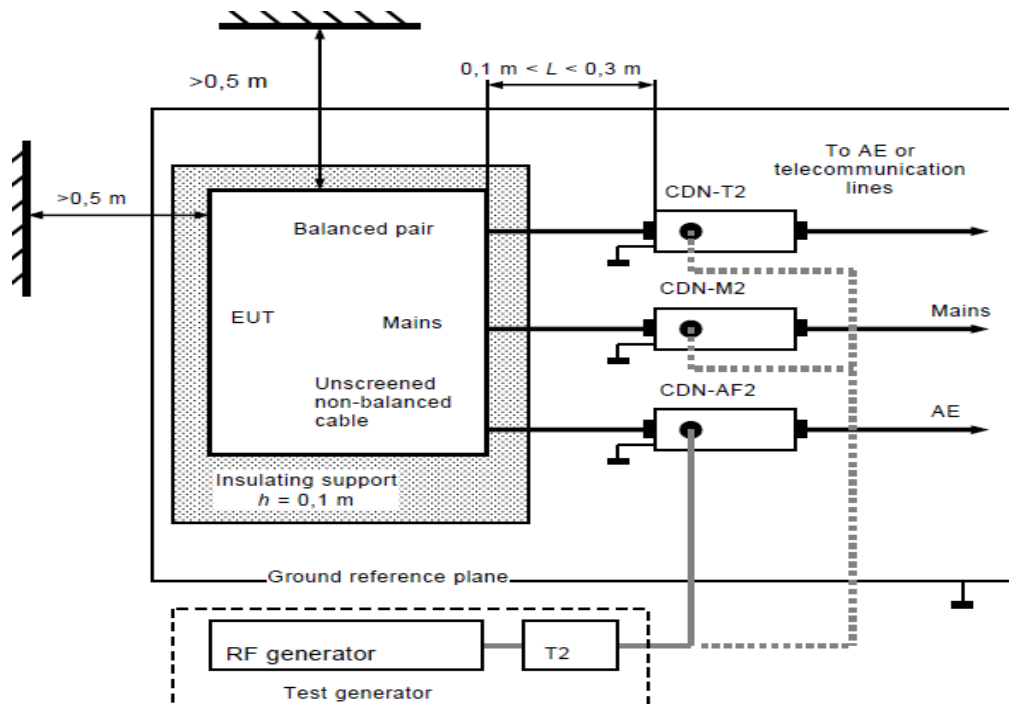

Note: 1. The CDNs and / or EM clamp used for real test depends on ports and cables configuration of EUT.
 2. The EUT clearance from any metallic obstacles shall be at least 0.5m

- For the actual test configuration, please refer to the related item – Photographs of the Test Configuration.

NOTE:
 TABLE-TOP AND FLOOR-STANDING EQUIPMENT

The equipment to be tested is placed on an insulating support of 0.1 meters height above a ground reference plane. All relevant cables shall be provided with the appropriate coupling and decoupling devices at a distance between 0.1 meters and 0.3 meters from the projected geometry of the EUT on the ground reference plane.

8.7.5. TEST RESULTS

Temperature	22°C	Humidity	53% RH
Pressure	1009mbar	Tested By	David Cheng
Required Passing Performance		Criterion A	

Frequency Band (MHz)	Field Strength (Vrms)	Cable	Injection Method	Performance Criterion	Observation	Result
0.15 ~ 80	3	AC Power Line (0.3m)	CDN-M3	<input checked="" type="checkbox"/> A <input type="checkbox"/> B	Note <input checked="" type="checkbox"/> 1 <input type="checkbox"/> 2	PASS
0.15 ~ 80	3	RJ45 Line (0.3m)	CDN-T8	<input checked="" type="checkbox"/> A <input type="checkbox"/> B	Note <input checked="" type="checkbox"/> 1 <input type="checkbox"/> 2	PASS

NOTE: 1. There was no change compared with initial operation during the test.

8.8. POWER FREQUENCY MAGNETIC FIELD

8.8.1. TEST SPECIFICATION

Basic Standard:	IEC 61000-4-8
Frequency Range:	50Hz
Field Strength:	1 A/m
Observation Time:	1 minute
Inductance Coil:	Rectangular type, 1mx1m

8.8.2. TEST INSTRUMENT

Immunity Shield Room				
Name of Equipment	Manufacturer	Model	Serial Number	Calibration Due

NOTE: 1. The calibration interval of the above test instruments is 12 months and the calibrations are traceable to NML/ROC and NIST/USA.
 2. N.C.R.= No Calibration required.

8.8.3. TEST PROCEDURE (please refer to measurement standard or CCS SOP PA-027)

- a. The equipment is configured and connected to satisfy its functional requirements. It shall be placed on the GRP with the interposition of a 0.1m-thick insulating support.
- b. The equipment cabinets shall be connected to the safety earth directly on the GRP via the earth terminal of the EUT.
- c. The power supply, input and output circuits shall be connected to the sources of power supply, control and signal.
- d. The cables supplied or recommended by the equipment manufacturer shall be used. 1 meter of all cables used shall be exposed to the magnetic field.

8.8.4. TEST SETUP

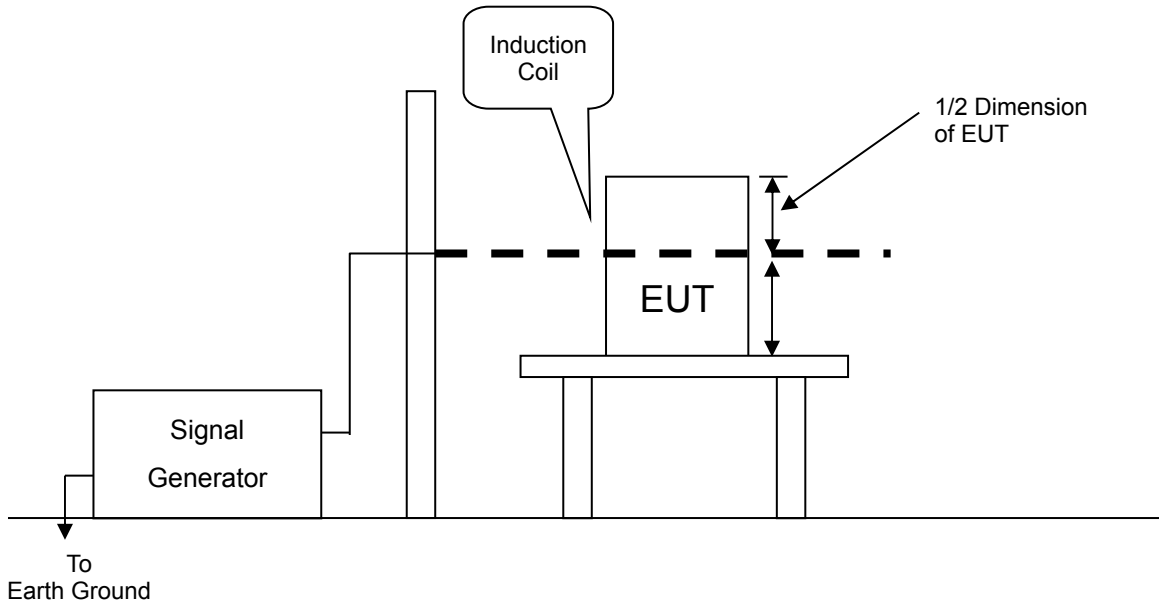

- For the actual test configuration, please refer to the related item – Photographs of the Test Configuration.

NOTE:

TABLETOP EQUIPMENT

The equipment shall be subjected to the test magnetic field by using the induction coil of standard dimension (1 m x 1 m). The induction coil shall then be rotated by 90 degrees in order to expose the EUT to the test field with different orientations.

FLOOR-STANDING EQUIPMENT

The equipment shall be subjected to the test magnetic field by using induction coils of suitable dimensions. The test shall be repeated by moving and shifting the induction coils, in order to test the whole volume of the EUT for each orthogonal direction. The test shall be repeated with the coil shifted to different positions along the side of the EUT, in steps corresponding to 50 % of the shortest side of the coil. The induction coil shall then be rotated by 90 degrees in order to expose the EUT to the test field with different orientations.

8.8.5. TEST RESULTS

Temperature	N/A	Humidity	N/A
Pressure	N/A	Tested By	N/A
Required Passing Performance		Criterion A	

DIRECTION	Field Strength (A/m)	Performance Criterion	OBSERVATION	RESULTS
X	1	A	Note	N/A
Y	1	A	Note	N/A
Z	1	A	Note	N/A

NOTE: There is no any sensitive part for magnetic field test. Applicable only to equipment containing susceptible to magnetic field.

8.9. VOLTAGE DIPS & VOLTAGE INTERRUPTIONS

8.9.1. TEST SPECIFICATION

Basic Standard:	IEC 61000-4-11
Test duration time:	Minimum three test events in sequence
Interval between event:	Minimum 10 seconds
Phase Angle:	0° / 180°
Test cycle:	3 times

8.9.2. TEST INSTRUMENT

Immunity shielded room				
Name of Equipment	Manufacturer	Model	Serial Number	Calibration Due
AC/DC Clamp Meter	Lutron	CM-9930R	I.200121	05/23/2018
EMC Immunity Tester	EMC Partner	TRANSINT 2000	1117	03/07/2018
Software	GenecsVer. 3.27			

NOTE: 1. The calibration interval of the above test instruments is 12 months and the calibrations are traceable to NML/ROC and NIST/USA.
 2. N.C.R.= No Calibration required.

8.9.3. TEST PROCEDURE (please refer to measurement standard or CCS SOP PA-028)

1. The EUT and support units were located on a wooden table, 0.8 m away from ground floor.
2. Setting the parameter of tests and then perform the test software of test simulator.
3. Conditions changes to occur at 0 degree crossover point of the voltage waveform.
4. Recording the test result in test record form.

8.9.4. TEST SETUP

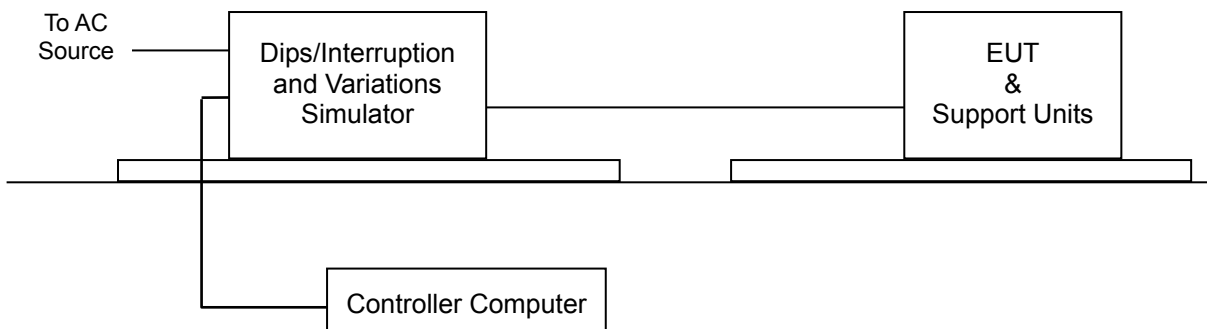

- For the actual test configuration, please refer to the related item – Photographs of the Test Configuration.

8.9.5. TEST RESULTS

Temperature	22°C	Humidity	53% RH
Pressure	1009mbar	Tested By	David Cheng
Required Passing Performance	Criterion B: >95% reduction 0.5 period Criterion C: 30% reduction 25 period & >95% reduction 250 period		

Test Power: 230Vac, 50Hz				
Voltage (% Reduction)	Duration (Period)	Performance Criterion	Observation	Test Result
>95	0.5	<input checked="" type="checkbox"/> A <input type="checkbox"/> B <input type="checkbox"/> C	Note <input checked="" type="checkbox"/> 1 <input type="checkbox"/> 2	PASS
30	25	<input checked="" type="checkbox"/> A <input type="checkbox"/> B <input type="checkbox"/> C	Note <input checked="" type="checkbox"/> 1 <input type="checkbox"/> 2	PASS
>95	250	<input type="checkbox"/> A <input type="checkbox"/> B <input checked="" type="checkbox"/> C	Note <input type="checkbox"/> 1 <input checked="" type="checkbox"/> 2	PASS

- NOTE:** 1. There was no change compared with initial operation during and after the test. No unintentional response was found during the test.
 2. EUT shut down, it could not become normal except reinstalled by operator.

9 PHOTOGRAPHS OF THE TEST CONFIGURATION CONDUCTED EMISSION TEST



**CONDUCTED EMISSION TEST AT TELECOMMUNICATION PORTS
RJ45 Telecom Port with ISN (10Mbps & 100Mbps & 1Gbps)**



RADIATED EMISSION TEST



Harmonic & Flicker Test

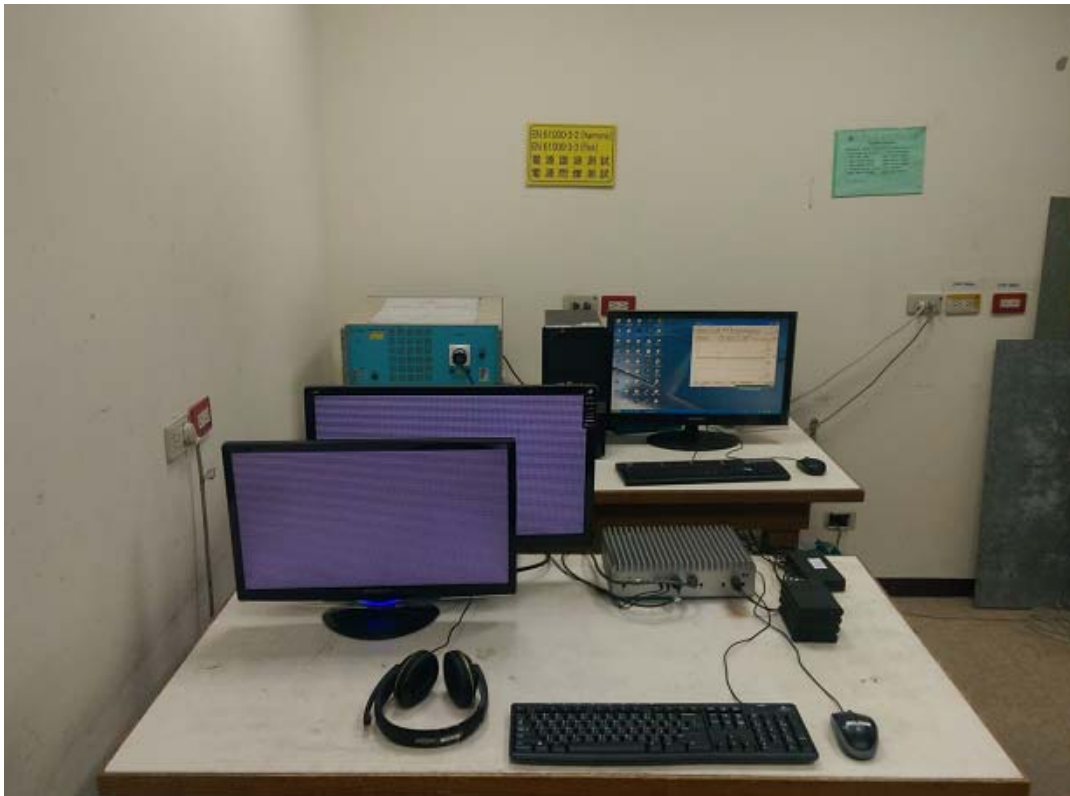

ESD Test



RS Test



EFT Test

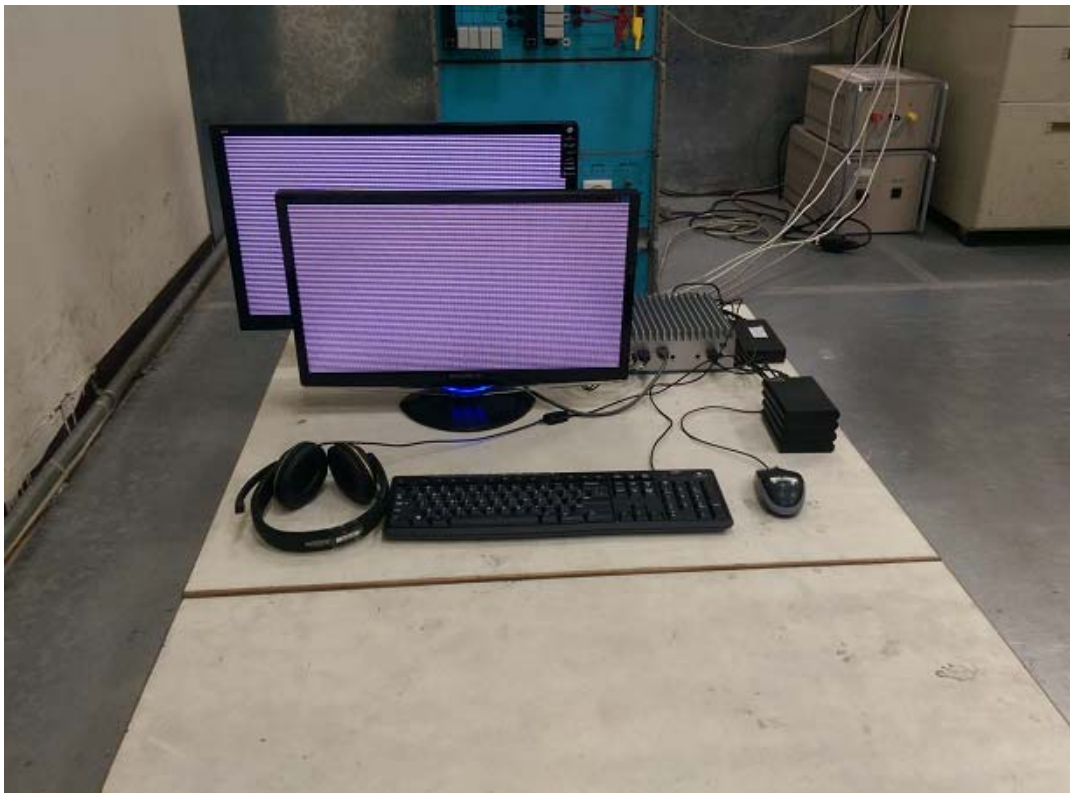

EFT For I/O Test



Surge Test

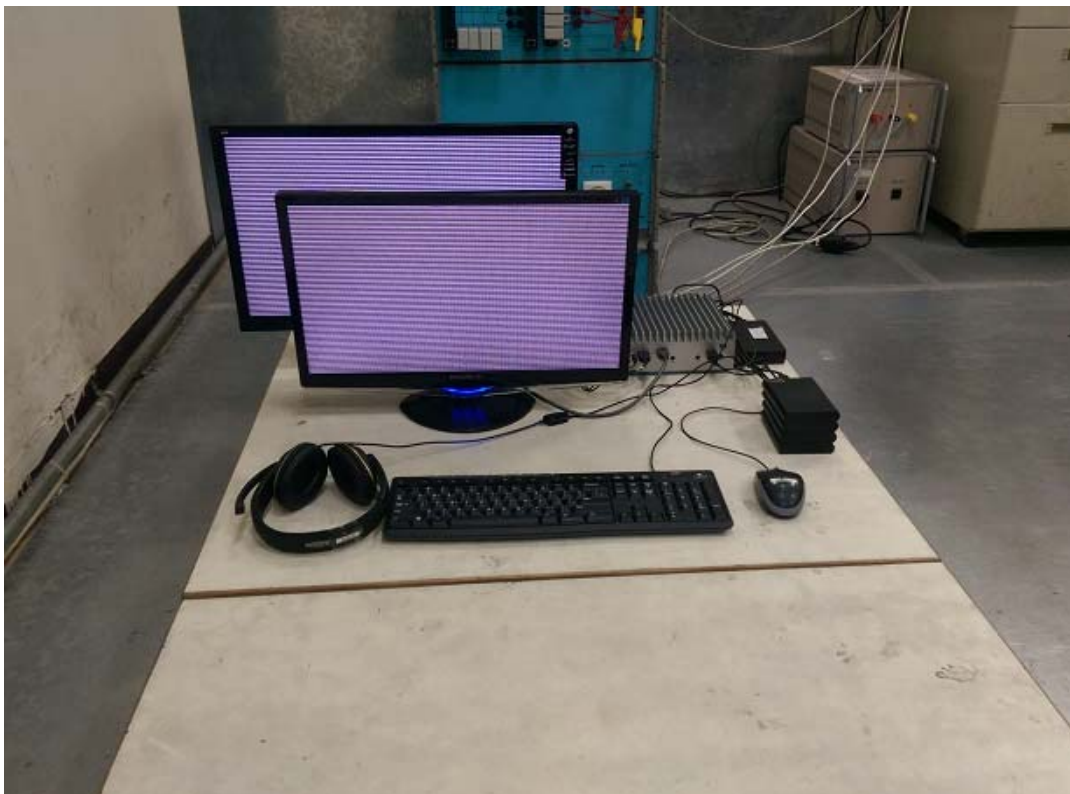

Surge For I/O Test



CS Test

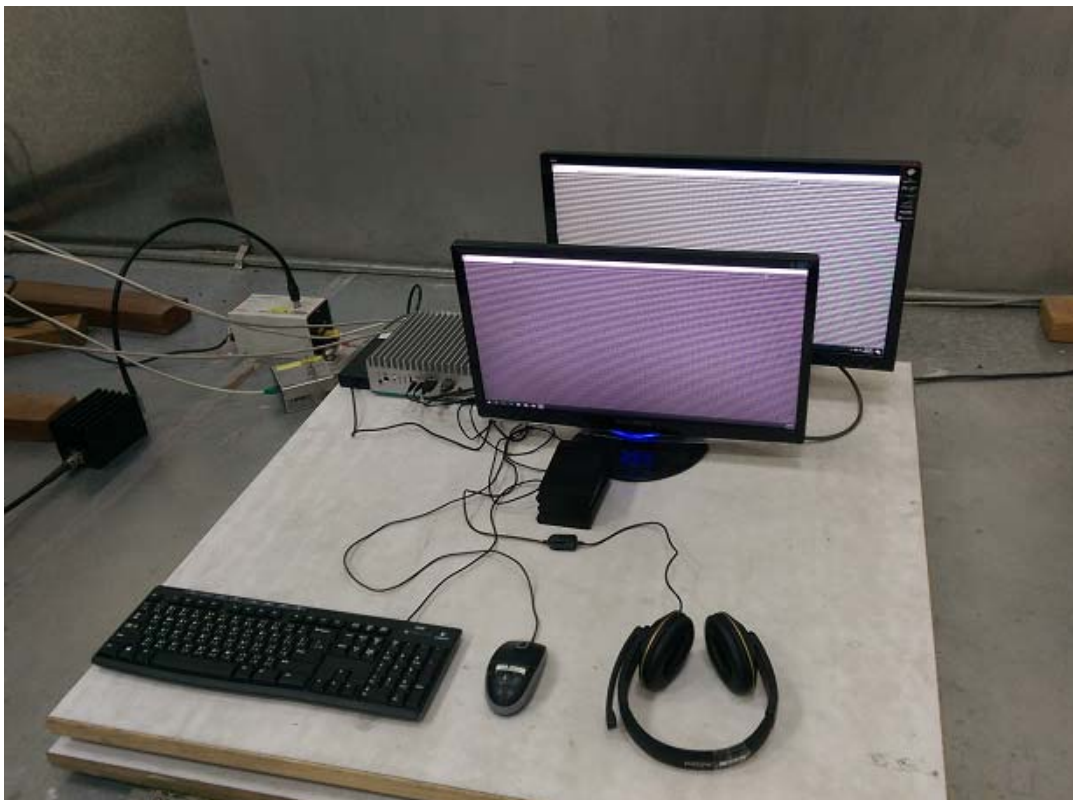

CS For I/O Test



Voltage Dips / Interruptions Test

